

COMe-mAS10 (E2)

Rev 1.3

This page has been intentionally left blank

User Guide - COMe-mAS10 (E2)

Disclaimer

congatec would like to point out that the information contained in this user guide may be subject to alteration, particularly as a result of the constant upgrading of congatec products. This document does not entail any guarantee on the part of congatec with respect to technical processes described in the user guide or any product characteristics set out in the user guide. congatec assumes no responsibility or liability for the use of the described product(s), conveys no license or title under any patent, copyright or mask work rights to these products and makes no representations or warranties that these products are free from patent, copyright or mask work right infringement unless otherwise specified. Applications that are described in this user guide are for illustration purposes only. congatec makes no representation or warranty that such application will be suitable for the specified use without further testing or modification. congatec expressly informs the user that this user guide only contains a general description of processes and instructions which may not be applicable in every individual case. In cases of doubt, please contact congatec.

This user guide is protected by copyright. All rights are reserved by congatec. No part of this document may be reproduced, transmitted, transcribed, stored in a retrieval system, or translated into any language or computer language, in any form or by any means (electronic, mechanical, photocopying, recording, or otherwise), without the express written permission of congatec. congatec points out that the information contained in this user guide is constantly being updated in line with the technical alterations and improvements made by congatec to the products and thus this user guide only reflects the technical status of the products by congatec at the time of publishing.

Brand and product names are trademarks or registered trademarks of their respective owners.

©2025 by congatec GmbH

congatec GmbH
Brunnwiesenstrasse 16
94469 Deggendorf
Germany
www.congatec.com

Intended Use

This device and associated software are not designed, manufactured or intended for use or resale for the operation of nuclear facilities, the navigation, control or communication systems for aircraft or other transportation, air traffic control, life support or life sustaining applications, weapons systems, or any other application in a hazardous environment, or requiring fail-safe performance, or in which the failure of products could lead directly to death, personal injury, or severe physical or environmental damage (collectively, “high risk applications”).

You understand and agree that your use of congatec devices as a component in High Risk Applications is entirely at your risk. To minimize the risks associated with your products and applications, you should provide adequate design and operating safeguards. You are solely responsible for compliance with all legal, regulatory, safety, and security related requirements concerning your products. You are responsible to ensure that your systems (and any congatec hardware or software components incorporated in your systems) meet all applicable requirements. Unless otherwise stated in the product documentation, the congatec device is not provided with error-tolerance capabilities and cannot therefore be deemed as being engineered, manufactured or setup to be compliant for implementation or for resale as device in High Risk Applications. All application and safety related information in this document (including application descriptions, suggested safety measures, suggested JUMPttec products, and other materials) is provided for reference only.

NOTICE

You find the most recent version of the “General Safety Instructions“ online in the download area of this product on our [congatec website](#).

NOTICE

This product is not intended for use or suited for storage or operation in corrosive environments, in particular under exposure to sulfur and chlorine and their compounds. For information on how to harden electronics and mechanics against these stress conditions, contact congatec Support.

Revision History

Revision	Brief Description of Changes	Date of Issue	Author
1.0	Release version	28.02.2025	IH
1.1	Added USB 2.0 comments	10.03.2025	IH
1.2	Updated UL registration number, + others	25.07.2025	IH
1.3	Corrected typo	03.09.2025	IH

Terms and Conditions

congatec warrants products in accordance with defined regional warranty periods. For more information about warranty compliance and conformity, and the warranty period in your region, visit <https://www.congatec.com/en/terms-and-conditions>.

congatec sells products worldwide and declares regional General Terms & Conditions of Sale, and Purchase Order Terms & Conditions. Visit <https://www.congatec.com/en/terms-and-conditions>.

For contact information, refer to the corporate offices contact information on the last page of this user guide or visit our website [CONTACT US](#).

Customer Support

Find congatec contacts by visiting <https://www.congatec.com/en/service-support>.

Customer Service

As a trusted technology innovator and global solutions provider, congatec extends its embedded market strengths into a services portfolio allowing companies to break the barriers of traditional product lifecycles. Proven product expertise coupled with collaborative and highly-experienced support enables congatec to provide exceptional peace of mind to build and maintain successful products.

For more details on JUMPtéc's service offerings such as: enhanced repair services, extended warranty, congatec training academy, and more visit <https://www.congatec.com/en/service-support>.

Customer Comments

If you have any difficulties using this user guide, discover an error, or just want to provide some feedback, contact [congatec Support](#). Detail any errors you find. We will correct the errors or problems as soon as possible and post the revised user guide on our website.

Symbols

The following symbols may be used in this user guide



DANGER indicates a hazardous situation which, if not avoided, will result in death or serious injury.



WARNING indicates a hazardous situation which, if not avoided, could result in death or serious injury.



NOTICE indicates a property damage message.



CAUTION indicates a hazardous situation which, if not avoided, may result in minor or moderate injury

ATTENTION indique une situation dangereuse qui, si elle n'est pas évitée, peut entraîner des blessures mineures ou modérées.



Electric Shock!

This symbol and title warn of hazards due to electrical shocks (> 60 V) when touching products or parts of products. Failure to observe the precautions indicated and/or prescribed by the law may endanger your life/health and/or result in damage to your material.



ESD Sensitive Device!

This symbol and title inform that the electronic boards and their components are sensitive to static electricity. Care must therefore be taken during all handling operations and inspections of this product in order to ensure product integrity at all times.



Caution: HOT Surface!

Do NOT touch! Allow to cool before servicing.

Attention : Surface CHAUDE !

Ne pas toucher ! Laissez refroidir avant de procéder à l'entretien.



Caution: Laser!

This symbol inform of the risk of exposure to laser beam and light emitting devices (LEDs) from an electrical device. Eye protection per manufacturer notice shall review before servicing.



This symbol indicates general information about the product and the user guide.

This symbol also indicates detail information about the specific product configuration.



This symbol precedes helpful hints and tips for daily use.

For Your Safety

Your new congatec product was developed and tested carefully to provide all features necessary to ensure its compliance with electrical safety requirements. It was also designed for a long fault-free life. However, the life expectancy of your product can be drastically reduced by improper treatment during unpacking and installation. Therefore, in the interest of your own safety and of the correct operation of your new congatec product, you are requested to conform with the following guidelines.

High Voltage Safety Instructions

As a precaution and in case of danger, the power connector must be easily accessible. The power connector is the product's main disconnect device.

⚠ CAUTION

Warning

All operations on this product must be carried out by sufficiently skilled personnel only.

⚠ CAUTION

Electric Shock!

Before installing a non hot-swappable congatec product into a system always ensure that your mains power is switched off. This also applies to the installation of piggybacks. Serious electrical shock hazards can exist during all installation, repair, and maintenance operations on this product. Therefore, always unplug the power cable and any other cables which provide external voltages before performing any work on this product.

Earth ground connection to vehicle's chassis or a central grounding point shall remain connected. The earth ground cable shall be the last cable to be disconnected or the first cable to be connected when performing installation or removal procedures on this product.

Special Handling and Unpacking Instruction

NOTICE

ESD Sensitive Device!

Electronic boards and their components are sensitive to static electricity. Therefore, care must be taken during all handling operations and inspections of this product, in order to ensure product integrity at all times.

⚠ CAUTION

Handling and operation of the product is permitted only for trained personnel within a work place that is access controlled. Follow the "General Safety Instructions" supplied with the product.

Do not handle this product out of its protective enclosure while it is not used for operational purposes unless it is otherwise protected.

Whenever possible, unpack or pack this product only at EOS/ESD safe work stations. Where a safe work station is not guaranteed, it is important for the user to be electrically discharged before touching the product with his/her hands or tools. This is most easily done by touching a metal part of your system housing.

It is particularly important to observe standard anti-static precautions when changing piggybacks, ROM devices, jumper settings etc. If the product contains batteries for RTC or memory backup, ensure that the product is not placed on conductive surfaces, including anti-static plastics or sponges. They can cause short circuits and damage the batteries or conductive circuits on the product.

Lithium Battery Precautions

If your product is equipped with a lithium battery, take the following precautions when replacing the lithium battery.

⚠ CAUTION

Risk of Explosion if the lithium Battery is replaced by an incorrect Type. Dispose of used lithium batteries According to the instructions.

Risque d'explosion si la pile au lithium est remplacée par une pile de type incorrect.

Éliminez les piles au lithium usagées conformément aux instructions.

General Instructions on Usage

In order to maintain JUMPtec's product warranty, this product must not be altered or modified in any way. Changes or modifications to the product, that are not explicitly approved by congatec and described in this user guide or received from [congatec Support](#) as a special handling instruction, will void your warranty.

This product should only be installed in or connected to systems that fulfill all necessary technical and specific environmental requirements. This also applies to the operational temperature range of the specific board version that must not be exceeded. If batteries are present, their temperature restrictions must be taken into account.

In performing all necessary installation and application operations, only follow the instructions supplied by the present user guide.

Keep all the original packaging material for future storage or warranty shipments. If it is necessary to store or ship the product then re-pack it in the same manner as it was delivered.

Special care is necessary when handling or unpacking the product. See Special Handling and Unpacking Instruction.

Quality and Environmental Management

congatec aims to deliver reliable high-end products designed and built for quality, and aims to complying with environmental laws, regulations, and other environmentally oriented requirements. For more information regarding JUMPtec's quality and environmental responsibilities, visit <https://www.congatec.com/en/about-congatec/quality>.

Disposal and Recycling

JUMPtec's products are manufactured to satisfy environmental protection requirements where possible. Many of the components used are capable of being recycled. Final disposal of this product after its service life must be accomplished in accordance with applicable country, state, or local laws or regulations.

WEEE Compliance

The Waste Electrical and Electronic Equipment (WEEE) Directive aims to:

- Reduce waste arising from electrical and electronic equipment (EEE)
- Make producers of EEE responsible for the environmental impact of their products, especially when the product become waste
- Encourage separate collection and subsequent treatment, reuse, recovery, recycling and sound environmental disposal of EEE
- Improve the environmental performance of all those involved during the lifecycle of EEE



Environmental protection is a high priority with congatec follows the WEEE directive

You are encouraged to return our products for proper disposal.

Table of Contents

Revision History	5
Terms and Conditions	5
Customer Support	5
Customer Service	5
Customer Comments	5
Symbols	6
For Your Safety	7
High Voltage Safety Instructions	7
Special Handling and Unpacking Instruction	7
Lithium Battery Precautions	7
General Instructions on Usage	8
Quality and Environmental Management	8
Disposal and Recycling	8
WEEE Compliance.....	8
Table of Contents	9
List of Tables.....	11
List of Figures	12
1/ General Safety Instructions	13
1.1. Electrostatic Discharge (ESD).....	14
1.2. Grounding Methods	14
1.3. Instructions for Lithium Battery	14
2/ Product Introduction	16
2.1. Product Naming Clarification	16
2.2. Product Description.....	16
2.3. COM Express® Documentation	16
2.4. COM Express® Type 10 Functionality	16
2.5. COM Express® Benefits	17
3/ Product Specification	18
3.1. Module Variants	18
3.1.1. Industrial Temperature Grade Modules (E2, -40°C to +85°C)	18
3.2. Accessories	18
3.2.1. Cooling	18
3.2.2. Evaluation Carrier	18
3.2.3. Others	19
3.3. Functional Specification	19
3.3.1. Technical Data	19
3.3.2. Block Diagram	20
3.3.3. Top Side	20
3.3.4. Bottom Side	21
3.3.5. Processor (CPU)	21
3.3.6. Plattform Controller Hub (PCH)	22
3.3.7. System Memory.....	23
3.3.8. High-Speed IO - HSIO Mapping.....	23
3.4. Interfaces.....	23
3.4.1. PCI Express Lanes.....	23
3.4.2. USB	23
3.4.3. SATA.....	24
3.4.4. Ethernet	24
3.4.5. Graphics Interface	24
3.4.6. Audio Interface	25
3.4.7. UART	25
3.4.8. General Purpose SPI Interface - GP_SPI.....	25
3.4.9. Boot SPI Interface	25
3.4.10. LPC/eSPI.....	26
3.4.11. I2C.....	27
3.4.12. GPIO	27
3.4.13. SMB.....	27
3.4.14. MIPI-CSI	27
3.5. Features.....	28
3.5.1. ACPI Power States	28
3.5.2. Embedded Controller - Hardware Monitor	28

3.5.3. Trusted Platform Module	29
3.5.4. Watchdog	29
3.5.5. Real-Time Clock (RTC)	29
3.5.6. eMMC	29
3.5.7. Boot SPI Device	30
3.5.8. Embedded EEPROM	30
3.5.9. Features on Request	30
3.6. Electrical Specification	30
3.6.1. Power Supply Specification	31
3.6.2. Power Management	31
3.6.3. Power Supply Modes	32
3.7. Thermal Management	33
3.7.1. Heatspreader Plate Assembly	33
3.7.2. Active/Passive Cooling Solutions	34
3.7.3. Operating with Heatspreader Plate (HSP) Assembly	34
3.7.4. Operating without Heatspreader Plate (HSP) Assembly	34
3.7.5. Temperature Sensors	34
3.7.6. On-Module Fan Connector	34
3.8. Mechanical Specification	35
3.8.1. Module Dimensions	35
3.8.2. Module Height	35
3.8.3. Heatspreader Plate Assembly Dimension	36
3.9. Environmental Specification	36
3.10. Compliance	36
3.11. MTBF	37
4/ COME Interface Connector	38
4.1. Connecting COME Interface Connector to Carrier Board	38
4.2. J1 Signals	38
4.3. Connector J1	39
4.3.1. Pins A1 - A110	39
4.3.2. Pins B1 - B110	42
4.3.3. Changes between COM.0 Rev 3.0 and Rev 3.1	45
5/ UEFI BIOS	46
5.1. Starting the UEFI BIOS	46
5.2. Navigating the UEFI BIOS	46
5.3. Setup Menus	46
5.4. Getting Help	47
5.5. UEFI Shell	47
5.5.1. Entering the UEFI Shell	47
5.5.2. Exiting the UEFI Shell	47
5.6. UEFI Shell Scripting	47
5.6.1. Startup Scripting	48
5.6.2. Create a Startup Script	48
5.6.3. Example of Startup Scripts	48
5.7. Firmware Update	48
6/ Technical Support	49
6.1. Warranty	49
6.2. Returning Defective Merchandise	49
7/ Storage and Transportation	50
7.1. Storage	50
7.2. Transportation	50

List of Tables

Table 1: COM Express® Product Naming Clarification	16
Table 2: COM Express® mini Type 10 and COMe-mAS10 (E2) functionality	16
Table 3: Product Number for Industrial Grade Modules (-40°C to +85°C)	18
Table 4: Cooling Equipment for COMe-mAS10 (E2)	18
Table 5: Evaluation Carrier	18
Table 6: Various	19
Table 7: Technical Data	19
Table 8: Intel® Atom x7000RE Product Family Specifications - standard on COMe-mAS10 (E2)	21
Table 9: Intel® Atom x7000E Product Family Specifications - on request for COMe-mAS10 (E2)	22
Table 10: DTR Table	22
Table 11: HSIO Mapping	23
Table 12: PCI Express	23
Table 13: USB 3.2 Gen2 / USB 2.0	24
Table 14: SATA Port Connections	24
Table 15: UART interfaces	25
Table 16: GP-SPI	25
Table 17: SPI	25
Table 18: LPC/eSPI mode comparison	26
Table 19: I2C Bus Port Address (I2C_EXT)	27
Table 20: MIPI-CSI Port 0	27
Table 21: MIPI-CSI Port 1	28
Table 22: ACPI Power States Function	28
Table 23: Watchdog signal on COMe connector	29
Table 24: Supported SPI Flash Devices	30
Table 25: Features on Request	30
Table 26: Power Supply Control Signals	32
Table 27: ATX Mode Settings	33
Table 28: Single Power Supply Mode Settings	33
Table 29: Heatspreader Temperature Specification	34
Table 30: Fan Connector (3-Pin) Pin Assignment	35
Table 31: Environmental Specification	36
Table 32: Compliance CE Mark	36
Table 33: Country Compliance	36
Table 34: MTBF	37
Table 35: General Signal Description	38
Table 36: Connector J1 Pins A1 - A110 according to COM-0 Rev 3.1	39
Table 37: Connector J1 Pins B1 - B110 according to COM-0 Rev 3.1	42
Table 38: Comparison Pinout Type 10 COM.0 Rev 3.0 vs. Rev 3.1	45
Table 39: Navigation Hot Keys Available in the Legend Bar	46

List of Figures

Figure 1: COMe-mAS10 (E2) Block Diagram.....	20
Figure 2: COMe-mAS10 (E2) Front Side	20
Figure 3: COMe-mAS10 (E2) Bottom Side	21
Figure 4: Module Temperature Sensors.....	34
Figure 5: Module Dimensions	35
Figure 6: Module and Carrier Height with 5 and 8mm connector height	36
Figure 7: Setup Menu Selection Bar	47

1/General Safety Instructions

Please read this passage carefully and take careful note of the instructions, which have been compiled for your safety and to ensure to apply in accordance with intended regulations. If the following general safety instructions are not observed, it could lead to injuries to the operator and/or damage of the product; in cases of non-observance of the instructions JUMPttec is exempt from accident liability, this also applies during the warranty period.

The product has been built and tested according to the basic safety requirements for low voltage (LVD) applications and has left the manufacturer in safety-related, flawless condition. To maintain this condition and to also ensure safe operation, the operator must not only observe the correct operating conditions for the product but also the following general safety instructions:

- The product must be used as specified in the product documentation, in which the instructions for safety for the product and for the operator are described. These contain guidelines for setting up, installation and assembly, maintenance, transport or storage.
- The on-site electrical installation must meet the requirements of the country's specific local regulations.
- If a power cable comes with the product, only this cable should be used. Do not use an extension cable to connect the product.
- To guarantee that sufficient air circulation is available to cool the product, please ensure that the ventilation openings are not covered or blocked. If a filter mat is provided, this should be cleaned regularly. Do not place the product close to heat sources or damp places. Make sure the product is well ventilated.
- Only connect the product to an external power supply providing the voltage type (AC or DC) and the input power (max. current) specified on the JUMPttec Product Label and meeting the requirements of the Limited Power Source (LPS) and Power Source (PS2) of UL/IEC 62368-1 .
- Only products or parts that meet the requirements for Power Source (PS1) of UL/IEC 62368-1 may be connected to the product's available interfaces (I/O).
- Before opening the product, make sure that the product is disconnected from the mains.
- Switching off the product by its power button does not disconnect it from the mains. Complete disconnection is only possible if the power cable is removed from the wall plug or from the product. Ensure that there is free and easy access to enable disconnection.
- The product may only be opened for the insertion or removal of add-on cards (depending on the configuration of the product). This may only be carried out by qualified operators.
- If extensions are being carried out, the following must be observed:
 - all effective legal regulations and all technical data are adhered to
 - the power consumption of any add-on card does not exceed the specified limitations
 - the current consumption of the product does not exceed the value stated on the product label
- Only original accessories that have been approved by JUMPttec can be used.
- Please note: safe operation is no longer possible when any of the following applies:
 - the product has visible damages or
 - the product is no longer functioningIn this case the product must be switched off and it must be ensured that the product can no longer be operated.
- Handling and operation of the product is permitted only for trained personnel within a work place that is access controlled.
- CAUTION: Risk of explosion if the lithium battery is replaced incorrectly (short-circuited, reverse-poled, wrong lithium battery type). Dispose of used lithium batteries according to the manufacturer's instructions.
- This product is not suitable for use in locations where children are likely to be present

Additional Safety Instructions for DC Power Supply Circuits

- To guarantee safe operation, please observe that:
 - the external DC power supply must meet the criteria for LPS and PS2 (UL/IEC 62368-1)
 - no cables or parts without insulation in electrical circuits with dangerous voltage or power should be touched directly or indirectly

- › a reliable functional earth connection is provided
- › a suitable, easily accessible disconnecting device is used in the application (e.g. overcurrent protective device), if the product itself is not disconnect able
- › a disconnect device, if provided in or as part of the product, shall disconnect both poles simultaneously
- › interconnecting power circuits of different products cause no electrical hazards
- › A sufficient dimensioning of the power cable wires must be selected – according to the maximum electrical specifications on the product label – as stipulated by EN62368-1 or VDE0100 or EN60204 or UL61010-1 regulations.

For the General Safety Instruction in German or French, visit JUMPtec's product web page> Downloads> Manuals> General Safety Instructions.

1.1. Electrostatic Discharge (ESD)

A sudden discharge of electrostatic electricity can destroy static-sensitive devices or micro-circuitry. Therefore, proper packaging and grounding techniques are necessary precautions to prevent damage. Always take the following precautions:



ESD Sensitive Device!

Keep electrostatic sensitive parts in their containers until they arrive at the ESD-safe workplace. Always be properly grounded when touching a sensitive board, component, or assembly.

For more Information, see the Special Handling and Unpacking Instruction within this user guide and the following Chapter Grounding Methods.

1.2. Grounding Methods

The following measures help to avoid electrostatic damages to the device:

- › Cover workstations with approved antistatic material. Always wear a wrist strap connected to the workplace, as well as properly grounded tools and equipment.
- › Use antistatic mats, heel straps, or air ionizers for more protection.
- › Always handle electrostatically sensitive components by their edge or by their casing.
- › Avoid contact with pins, leads, or circuitry.
- › Switch off power and input signals before inserting and removing connectors or connecting test equipment.
- › Keep the work area free of non-conductive materials such as ordinary plastic assembly aids and styrofoam.
- › Use field service tools such as cutters, screwdrivers, and vacuum cleaners that are conductive.
- › Always place drives and boards with the PCB-assembly-side down on the foam.

1.3. Instructions for Lithium Battery

If the product is equipped with a lithium battery, there is a risk of explosion if the lithium battery is replaced incorrectly (short-circuited, reverse-poled, wrong lithium battery type). Dispose of used batteries according to the manufacturer's instructions.

CAUTION

Risk of Explosion if the lithium battery is replaced by an incorrect Type. Dispose of used batteries according to the instructions.

Risque d'explosion si la pile au lithium est remplacée par une pile de type incorrect.

Éliminez les piles au lithium usagées conformément aux instructions



Do not dispose of lithium batteries in general trash collection. Dispose of the lithium battery according to the local regulations dealing with the disposal of these special materials, (e.g. to the collecting points for dispose of batteries).

2/Product Introduction

This user guide describes the COM Express® mini Computer-on-Module COMe-mAS10 (E2) made by JUMPTec and focuses on describing the module's special features. JUMPTec recommends users to study this user guide before powering on the module.

2.1. Product Naming Clarification

Table 1: COM Express® Product Naming Clarification

Standard short form	Module form factor	Processor family identifier	Pinout type	Available temperature variants
COMe-	b= basic (125mm x 95mm) c= compact (95mm x 95mm) m= mini (84mm x 55mm)	EL = Elkhart Lake RP = Raptor Lake AS = Amston Lake etc.	6 = Type 6 7 = Type 7 10 = Type 10	none = Commercial Extended (E1) Industrial (E2) Screened industrial (E2S)

2.2. Product Description

The COMe-mAS10 (E2) is a small form factor COM Express® Type 10 Computer-On-Module designed for flexible implementation within multiple embedded industrial environments. The COMe-mAS10 (E2) is based on the Intel® Atom™ processors (Codename: Amston Lake & Alder Lake N) with an integrated PCH to combine increased efficiency and performance with TDP as low as 6 W and no more than 12 W, including Intel's® extensive HD Graphics capabilities.

Key features are:

- › Small form-factor COM Express® mini Type 10 pinout, compatible with PICMG COM.0 Rev 3.1 spec
- › Up to 16 GByte LPDDR5 memory down (with in-band ECC)
- › High-speed connectivity: 4x PCI Express, 1x 1 Gb Ethernet, 2x USB 3.1 + 6x USB 2.0, 2x SATA Gen.3
- › Support for Industrial and commercial temperature grade environments

2.3. COM Express® Documentation

The COM Express® specification defines the COM Express® module form factor, pinout and signals. For more COM Express® specification information, please visit the [PCI Industrial Computer Manufacturers Group \(PICMG®\)](https://www.picmg.org/) website.

2.4. COM Express® Type 10 Functionality

All JUMPTec COM Express® mini modules contain a single 220-pin connector with two rows called row A & B. The COM Express® mini Type 10 Computer-On-Module features the following maximum amount of interfaces according to the PICMG module pinout type.

Table 2: COM Express® mini Type 10 and COMe-mAS10 (E2) functionality

Interface	COM Express mini Type 10 min/max	COMe-mAS10 (E2)	Comment
PCI Express Lanes 0 - 5	1/4	4	
NBASE-T	1 /1	1	Default 1GBASE-T, optional 2.5GBASE-T
DDI 0	0/1	1	
Single Channel LVDS	0/1	1	
eDP on LVDS CH A pins	0/1	1	Optional
MIPI-CSI connectors	0/2	2	Optional
Serial 0,1	0/2	2	
CAN on Ser1	0/1	0	
SATA	0/2	2	
HD Audio	0/1	1	
Soundwire	0/1	1	Optional

USB 2.0	4/8	8	
USB Client	0/1	0	Cable length < 3m recommended
USB 3.2 Gen1 or Gen2	0/2	2 USB 3.2 Gen2	Up to USB 3.2 Gen2 with re-timer on carrier
LPC or eSPI	1/1	1	Default LPC, optional eSPI
BOOT_SPI	1/1	1	
GP_SPI	0/1	1	
SMB	1/1	1	
GPIO	8/8	8	

2.5. COM Express® Benefits

COM Express® defines a Computer-On-Module (COM), with all the components necessary for a bootable host computer, packaged as a highly integrated computer. All JUMPtec COM Express® modules are very compact and feature a standardized form factor and a standardized connector layout that carry a specified set of signals. Each COM module is based on the COM Express® specification. This standardization allows designers to create a single-system carrier board that can accept present and future COM Express® modules. The carrier board designer can optimize exactly how each of these functions implements physically. Designers can place connectors precisely where needed for the application, on a carrier board optimally designed to fit a system's packaging. A single carrier board design can use a range of COM Express® modules with different sizes and pinouts. This flexibility differentiates products at various price and performance points and provides a built-in upgrade path when designing future-proof systems. The modularity of a COM Express® solution also ensures against obsolescence when computer technology evolves. A properly designed COM Express® carrier board can work with several successive generations of COM Express® modules. A COM Express® carrier board design has many advantages of a customized computer-board design and, additionally, delivers better obsolescence protection, heavily reduced engineering effort, and faster time to market.

3/Product Specification

3.1. Module Variants

3.1.1. Industrial Temperature Grade Modules (E2, -40°C to +85°C)

Table 3: Product Number for Industrial Grade Modules (-40°C to +85°C)

Part Number	Product Name	CPU	Memory	eMMC TLC	Use Condition
34017-0432-R1-2	COMe-mAS10 E2 x7211RE 4G/32G	x7211RE	4GB	32GB	embedded* / industrial, extended temperature
34017-0432-R2-2	COMe-mAS10 E2 x7213RE 4G/32G	x7213RE	4GB	32GB	embedded* / industrial, extended temperature
34017-0432-R2-4	COMe-mAS10 E2 x7433RE 4G/32G	x7433RE	4GB	32GB	embedded* / industrial, extended temperature
34017-0832-R2-8	COMe-mAS10 E2 x7835RE 8G/32G	x7835RE	8GB	32GB	embedded* / industrial, extended temperature
34017-1632-R2-8	COMe-mAS10 E2 x7835RE 16G/32G	x7835RE	16GB	32GB	embedded* / industrial, extended temperature

* Default configuration of the module is embedded

3.2. Accessories

Accessories are product specific, COM Express® specific or general COM accessories. For more information, contact your local JUMPtec Sales Representative or JUMPtec Inside Sales.

3.2.1. Cooling

A standard heat spreader solutions can be used, which are available in a threaded and non-threaded (through hole) version.

Table 4: Cooling Equipment for COMe-mAS10 (E2)

P/N	Product Name	Description
34017-0000-99-0	HSP COMe-mAS10 (E2) thread	Heatspreader for COMe-mAS10 commercial and E2, threaded mounting
34017-0000-99-1	HSP COMe-mAS10 (E2) through	Heatspreader for COMe-mAS10 commercial and E2, through mounting holes
34017-0000-99-2	HSP COMe-mAS10 (E2) slim thread	Heatspreader for COMe-mAS10 slim commercial and E2, threaded mounting
34017-0000-99-3	HSP COMe-mAS10 (E2) slim through	Heatspreader for COMe-mAS10 slim commercial and E2, through mounting holes
34099-0000-99-0	COMe mini Active uni-cooler	COM Express® mini universal active cooler for heatspreader mounting
34099-0000-99-1	COMe mini passive uni-cooler	COM Express® mini universal passive cooler for heatspreader mounting
34099-0000-99-3	COMe mini passive uni-cooler slim	COM Express® mini universal passive cooler slim for heatspreader mounting

3.2.2. Evaluation Carrier

Table 5: Evaluation Carrier

P/N	Product Name	Description
34101-0000-00-2	COMe Eval Carrier T10 Gen2	COM Express® Evaluation Carrier Type 10 Gen2
34101-0000-00-3	COMe Eval Carrier T10 Gen3	COM Express® Evaluation Carrier Type 10 Gen3

3.2.3. Others

Table 6: Various

P/N	Product Name	Description
96079-0000-00-0	KAB-HSP 200mm	Fan cable adapter for 3pin standard FAN connector to 3pin molex connector, cable length 200mm
96079-0000-00-2	KAB-HSP 40mm	Fan cable adapter for 3pin standard FAN connector to 3pin molex connector, cable length 40mm
34017-0000-00-0	COMe Mount Kit 5/8mm 1set	Mounting Kit for 1 module with screws for 5/8mm COMe connector

3.3. Functional Specification

3.3.1. Technical Data

Table 7: Technical Data

Function	Definition
Compliance	COM Express® Mini Pin-out Type 10
Dimension (H X W)	84 mm x 55 mm
Processors	Intel® Atom® x7000E / x7000RE Processor Series
Chipset	Integrated in SOC
Main Memory	Memory down for up to 16 GByte LPDDR5
Graphics Controller	Intel® UHD Graphics
Display	DDI1: DP++, LVDS: Single Channel 18/24bit, optional eDP
Ethernet Controller	GPY115 PHY (optional GPY215 PHY)
Ethernet	1 GBASE-T with TSN support, optional 2.5GBASE-T with GPY215
Storage	2x SATA 6 Gb/s
Flash On-board	eMMC 5.1 (up to 256 GByte TLC or 85 GByte pSLC)
PCI Express	4x PCIe Gen3
USB	2x USB 3.2 Gen2 (incl. USB 2.0) + 6x USB 2.0
Serial	2x serial interface (RX/TX) from embedded controller
Audio	High Definition Audio interface
Other Features	GP_SPI, SMB, Fast I ² C, Staged Watchdog, RTC
Special Features	Industrial grade temperature
Features on Request	eMMCS.1 - various capacities, 2.5GByte Ethernet (BASE-T) with GPY215 PHY, eSPI instead of LPC, eDP instead of LVDS, 2x UART from SOC instead of embedded controller, discrete TPM 2.0
Power Management	ACPI 6.0
Power Supply	4.75 V – 20 V Wide Range, Single Supply Power
BIOS	AMI UEFI
Operating Systems	Linux, Windows 10/11 IoT Enterprise LTSC
Temperature	Commercial temperature: 0 °C to +60 °C operating, -30 °C to +85 °C non-operating Industrial temperature: -40 °C to +80 °C operating, -40 °C to +85 °C non-operating
Humidity	93 % relative Humidity at 40 °C, non-condensing (according to IEC 60068-2-78)

3.3.2. Block Diagram

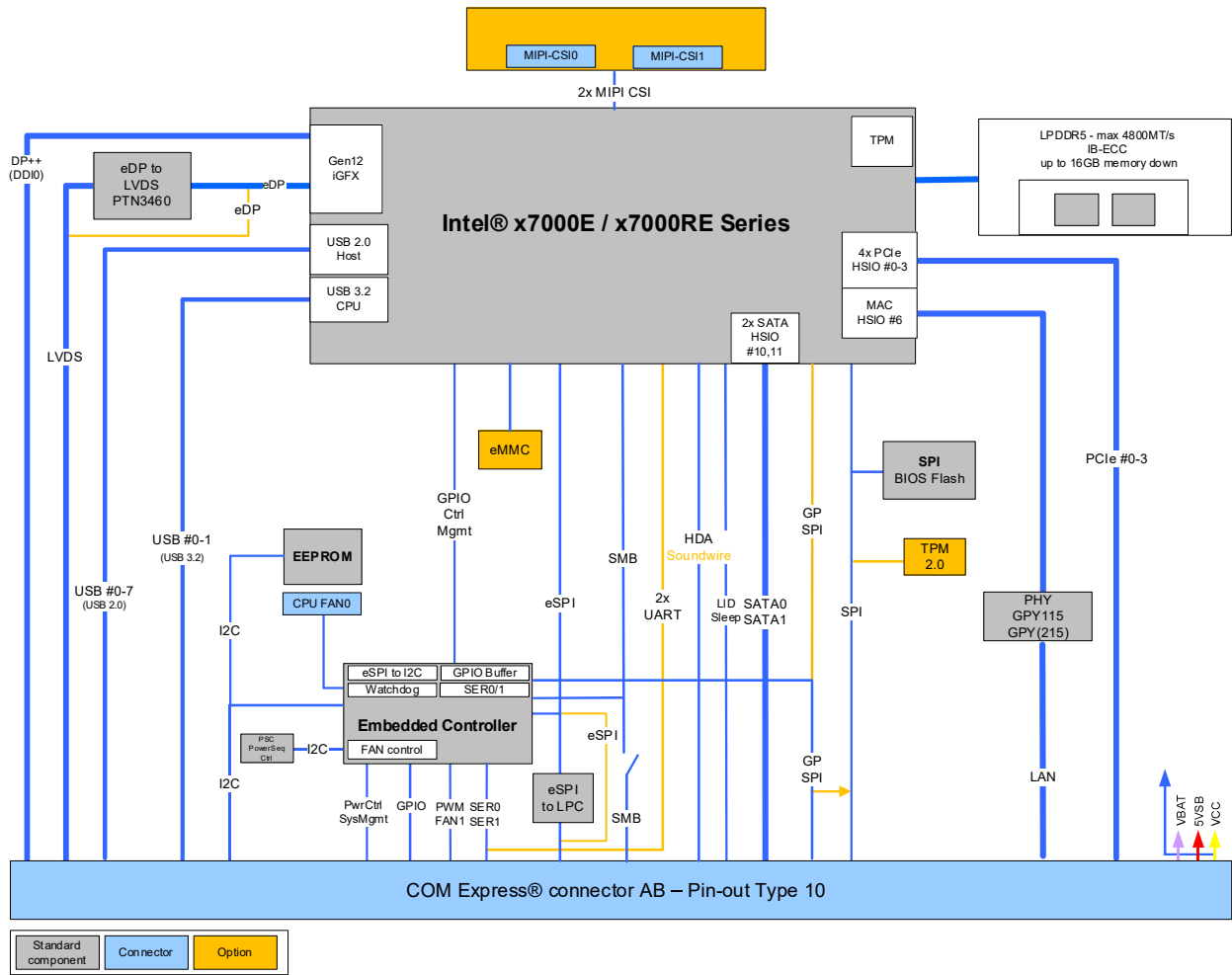

Figure 1: COMe-mAS10 (E2) Block Diagram

3.3.3. Top Side

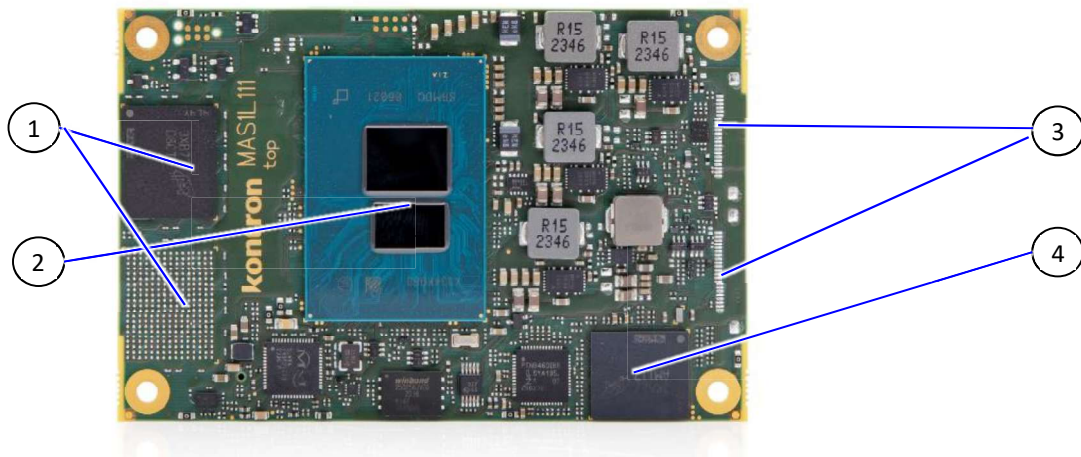

Figure 2: COMe-mAS10 (E2) Front Side

- | | |
|--|---|
| 1. LPDDR5 memory down | 3. Position of optional flatfoil connector for MIPI-CSI |
| 2. SoC - Processor (CPU) & Chipset (PCH) | 4. eMMC flash chip |

User Guide - COMe-mAS10 (E2)

3.3.4. Bottom Side

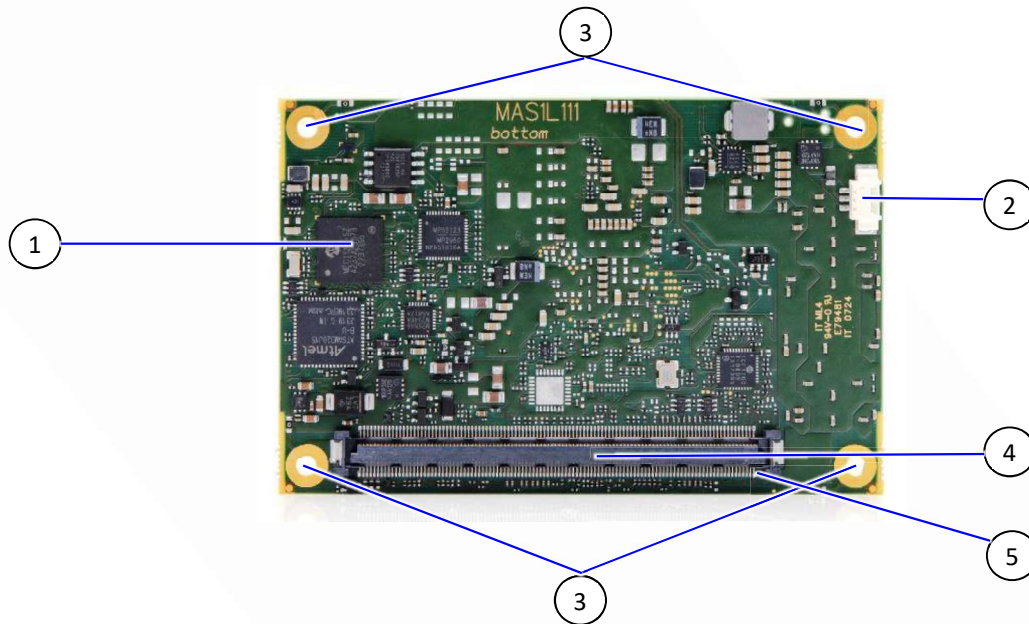

Figure 3: COMe-mAS10 (E2) Bottom Side

- 1. Embedded Controller
- 2. Fan connector
- 3. Four mounting holes - for heatspreader to module, module to carrier mounting
- 4. COM Express connector J1
- 5. Connector J1 - Pin A1

3.3.5. Processor (CPU)

The Intel Atom® x7000RE / x7000E processor series delivers power-efficient, ruggedized performance with up to eight Efficient-cores (E-cores), UHD Graphics driven by Xe architecture with up to 32 EUs. The processors supports Intel® Advanced Vector Extensions 2 (Intel® AVX2) and Intel® Deep Learning Boost (Intel® DL Boost) to accelerate compute-intensive operations and deep learning inference processing.

Table 8: Intel® Atom x7000RE Product Family Specifications - standard on COMe-mAS10 (E2)

Processor Number	TDP W	Cores	CPU			GPU			ECC	TCC	Tj min °C	Tj max °C	Use Condition
			Base GHz	1C Turbo GHz	MC Turbo GHz	EU	Base MHz	Turbo MHz					
x7211RE	6	2	1.0	3.2	2.9	16	400	1000	Yes-In Band	Yes	-40	105	Embedded Industrial
x7213RE	9	2	2.0	3.4	2.9	16	600	1000	Yes-In Band	Yes	-40	105	Embedded Industrial
x7433RE	9	4	1.5	3.4	2.7	32	600	1000	Yes-In Band	Yes	-40	105	Embedded Industrial
x7835RE	12	8	1.3	3.6	3.0	32	800	1200	Yes-In Band	Yes	-40	105	Embedded Industrial

Table 9: Intel® Atom x7000E Product Family Specifications - on request for COMe-mAS10 (E2)

Processor Number	TDP W	Cores	CPU			GPU			ECC	TCC	Tj min °C	Tj max °C	Use Condition
			Base GHz	1C Turbo GHz	MC Turbo GHz	EU	Base MHz	Turbo MHz					
x7211E	6	2	1.0	3.2	2.9	16	600	1000	No	Yes	0	105	Embedded
x7213E	10	2	1.7	3.2	2.9	16	800	1000	No	Yes	0	105	Embedded
x7425E	12	4	1.5	3.4	2.7	24	800	1000	No	Yes	0	105	Embedded

For the x7000RE/x7000E processor family the Dynamic Temperature Range (DTR) behavior applies. DTR is the temperature range the processor can operate in. The temperature range starts with the temperature of the processor (Tj = junction temperature) at boot time (TBoot) and can transition to a lower and/or higher temperature within the Tj min and Tj max limits.

- E.g.: Tj min = -40°, the Tj max = 100°C and the DTR = +-90°C
- TBoot = -40°C: the processor can operate from -40°C up to + 50°C
- TBoot = -20°C: the processor can operate from -40°C up to + 70°C
- TBoot = +20°C: the processor can operate from -40°C up to + 100°C

A Tj outside of the DTR range requires a cold reset but is not enforced by the hardware.

The DTR behavior is described in [Intel whitepaper 814861](#).

x7000RE Processor Series:

When the turbo is enabled then the Use Condition is Embedded and the DTR = +- 90°C.

For use as Industrial Use Condition the turbo needs to be disabled, then DTR = +- 110°C.

In addition for certain interfaces such as eMMC, USB, etc.. the speed needs to be reduced.

x7000E Processor Series:

Embedded Use Condition, DTR = +- 70°C.

Please contact [JUMPtec Support](#) for further information.

Table 10: DTR Table

CPU Use Condition	Commercial Temp: Embedded	Extended Temp: Embedded	Extended Temp: Industrial
CPU Tj min.	0°C	-40°C	-40°C
CPU Tj max.	105°C	105°C	105°C
DTR (Cold to Hot Transition)	TBoot + 70°C	TBoot + 90°C	TBoot + 110°C
DTR (Hot to Cold Transition)	TBoot - 70°C	TBoot - 90°C	TBoot - 110°C

3.3.6. Plattform Controller Hub (PCH)

The Intel Atom x7000RE and x7000E processor series supports an integrated PCH offering interfaces such as 9 HSIOs (High Speed IO lanes)

3.3.7. System Memory

The COMe-mAS10 (E2) supports up to 16 GByte LPDDR5 memory down (up to 4800MT/s).
The Intel Atom x7000RE and x7000E processor series supports in-band ECC.

3.3.8. High-Speed IO - HSIO Mapping

The integrated SoC PCH supports 9x HSIO lanes, which can be configured as PCIe Gen 3.0 lanes with a max of 5 RPC (Root Port Controller).

Partially the HSIOs are multi-pupose and can be alternatively configured as USB3.2 Gen2 or SATA.

Table 11: HSIO Mapping

Processor's HSIOs										
0	1	2	3		6		8	9	10	11
USB SuperSpeed					TSN LAN					
0	1	2	3							
PCIe						PCIe				
x1	x1	x1	x1			x1	x1	x1	x1	
								SATA		
								0	1	

Usage on COMe-mAS10 (A2)										
0	1	2	3		6		8	9	10	11
COMe PCIe #0	COMe PCIe #1	COMe PCIe #2	COMe PCIe #3		Onboard 1GbE (optional 2.5 GbE) PHY		N.C.	N.C.	COMe SATA #0	COMe SATA #1
x1	x1	x1	x1							
x2		x2								
x4										

3.4. Interfaces

3.4.1. PCI Express Lanes

COM Express® Type 10 modules support up to four PCI Express lanes.

The COMe-mAS10 (E2) supports four high-speed PCI Express 3.0 lanes PCIe [0-3], allowing for the connection of up to four separate external PCIe devices. The default PCIe configuration is (4 x1) with options for (2 x1 + 1 x2), (2 x2) and (1 x4).

See also [Chapter 3.3.8](#) HSIO Mapping

Table 12: PCI Express

COMe Connector	HSIO lane	Supported Lane Configuration			
		4 x1 (default)	2 x1 + 1 x2	2 x2	1 x4
PCIE_0	0	x1	x2	x2	x4
PCIE_1	1	x1			
PCIE_2	2	x1	x2		
PCIE_3	3	x1			



To change the default PCIe configuration (4x1), a new BIOS version is required. For BIOS version information, please visit JUMPTec's [Customer Section](#).

3.4.2. USB

COM Express® Type 10 boards provide up to eight USB 2.0 ports. Up to two of these can be used as USB 3.2 Gen1 or Gen2 ports.

Each USB 3.2 port implemented is comprised of a USB 2.0 port and an USB SuperSpeed TX pair and RX pair.

Therefore, the number of available USB 2.0 only ports decreases with every used USB 3.2 Gen1 or Gen2 port.

The COMe-mAS10 (E2) offers two USB 3.2 Gen2 ports with 10 Gb/s (including USB 2.0) and six dedicated USB 2.0 ports.

USB Ports	2x USB 3.2 Gen2 (up to 10 Gb/s) (USB 2.0 backwards compatible) 6x USB 2.0
USB Over Current Signals	4x

Table 13: USB 3.2 Gen2 / USB 2.0

COMe Connector	CPU	Description
USB_SS1	TCP0	USB-C Port used as USB 3.2 Gen2 (10 Gb/s)
USB_SS2	TCP1	USB-C Port used as USB 3.2 Gen2 (10 Gb/s)



When designing the carrier board consider the speed of the USB 3.2 Gen2 (10 Gb/s) ports. It is recommended to use a retimer/redriver on the carrier.

COMe Connector	PCH USB Port	Description
USB0	USB2_0	USB 2.0 port
USB1	USB2_1	USB 2.0 port
USB2	USB2_2	USB 2.0 port
USB3	USB2_3	USB 2.0 port
USB4	USB2_4	USB 2.0 port
USB5	USB2_5	USB 2.0 port
USB6	USB2_6	USB 2.0 port
USB7	USB2_7	USB 2.0 port



It is recommended to use a cable length < 3m for a proper USB 2.0 port communication.

3.4.3. SATA

COM Express® Type 10 modules support up to two SATA ports.

The COMe-mAS10 (E2) offers two SATA Gen3 ports with 6 Gb/s. (see also [Chapter 3.3.8](#) HSIO Mapping):

Table 14: SATA Port Connections

COMe Connector	HSIO Lane #	Description
SATA0	10	SATA Gen3, 6 Gb/s
SATA1	11	SATA Gen3, 6 Gb/s

3.4.4. Ethernet

COM Express® Type 10 modules support one NBASE-T Ethernet port.

The COMe-mAS10 (E2) supports one 1/2.5GBASE-T port.

HSIO lane #6 of the integrated SOC PCH is used as SGMII interface for the onboard 1GbE GPY115 (optionally 2.5GbE with GPY215) PHY (see [Chapter 3.3.8](#) HSIO Mapping).

3.4.5. Graphics Interface

The processor graphics is based on Generation 12 graphics core architecture. The Gen12 architecture supports up to 32 Execution Units (EUs) depending on the processor SKU.

The processor supports three simultaneous displays (Pipes A, B, C).

Processor	COMe Port	
DDI0 (Port A)	LVDS	eDP (option)
DDI1 (Port B)	DDI0 (DP++), for a resolution >4K a re-timer/re-driver is required on the carrier	
DDI2 (Port C)	Not used	

3.4.6. Audio Interface

The HDA signals of the processor are passed directly to COMe connector. SoundWire connections are optional available according to the COM.0 Rev3.1 specification.

3.4.7. UART

Two 3.3V logic level asynchronous two-wire serial ports, designated as SER0 and SER1 are defined by COM Express® Type 10 modules.

By default both serial ports are provided by the embedded controller. The module offers two additional connections to COMe serial port pins from the processor via resistor stuffing option.

1. UARTs from Embedded Controller
2. Optional UARTs provided by the processor

Hardware handshaking and hardware flow control are not supported.

The module asynchronous serial ports are intended for general purpose use and for use with debugging software that make use of the “console redirect” features available in many operating systems.

Table 15: UART interfaces

COMe Signal	Embedded Controller (default)	PCH (optional)
SER0_TX	UART0_TX	GPP_H11 / UART0_TDX
SER0_RX	UART0_RX	GPP_H10 / UART0_RDX
SER1_TX	UART1_TX	GPP_D18 / UART1_TDX
SER1_RX	UART1_RX	GPP_D17 / UART1_RDX

3.4.8. General Purpose SPI Interface - GP_SPI

The COM Express® specification Rev. 3.1 introduces a General Purpose Serial Peripheral Interface (GP_SPI) with dedicated pins (using RSVD pins of the former pinout) to connect multiple peripherals.

The GP_SPI signals are provided by the onboard embedded controller. As an assembly option the GP_SPI signals can be sourced alternatively from the PCH.

To maintain backward compatibility to predecessor designs, it's possible to connect the GP_SPI interface to COMe SPI pins via an assembly option as well.

Table 16: GP-SPI

COMe Signal	Optional COMe Signal
GP_SPI_CS# (A55)	SPI_CS# (B97)
GP_SPI_MISO (B55)	SPI_MISO (A92)
GP_SPI_MOSI (B56)	SPI_MOSI (A95)
GP_SPI_CLK (A56)	SPI_CLK (A94)

3.4.9. Boot SPI Interface

The processor's SPI0 interface is connecting to the onboard 32MB SPI flash and an optional TPM chip and further routed to the COMe SPI pins. This interface supports serial flash (for BIOS firmware) and TPM being attached to it only.

A BOM assembly option allows the General Purpose SPI (GP_SPI) to be connected to COMe signal pins instead. This option is implemented on request only.

Table 17: SPI

COMe Signal	PCH Pin (default)	PCH Pin (GP SPI option)
SPI_CS#	See table below	GPP_E10 / THCO_SPI1_CS# / GSPi0_CS0#

SPI_MISO	SPI0_MISO_IO0	GPP_E12 / THCO_SPI1_IO1 / I2COA_SDA / SPI0_MISO
SPI_MOSI	SPI0_MOSI_IO1	GPP_E13 / THCO_SPI1_IO0 / I2COA_SCL / GSPi0_MOSI
SPI_CLK	SPI0_CLK	GPP_E11 / THCO_SPI1_CLK / GSPi0_CLK
SPI_POWER	Connected to V_3V3_S5	
BIOS_DIS0#	Embedded Controller input to control SPI_CS# logic	
BIOS_DIS1#	Embedded Controller input to control SPI_CS# logic	

The COMe-mAS10 (E2) module supports on-module and carrier boot from SPI. The processor platform does not support Slave Attached File Sharing (SAFS) configurations (i.e. BIOS can't be attached to eSPI via an EC/BMC). COMe signals BIOS_DIS0#, BIOS_DIS1# and ESPI_EN# are used to select the desired boot source (see table below).

Config #	ESPI_EN#	BIOS_DIS1#	BIOS_DIS0#	Boot Bus	PCH CS1# (FSPI_CS1_N) to...	PCH CS0# (FSPI_CS0_N) to...	CS# to COMe Carrier	SPI Descriptor	Description
1	1	0	0	SPI	Carrier	Module	PCH CS1#	Module	MAFS on Module / LPC enabled
2	1	0	1	SPI	Module	Carrier	PCH CS0#	Carrier	MAFS on Carrier / LPC enabled
3	1	1	0	-	-	-	-	-	Not used – was FWH (works like #4)
4	1	1	1	SPI	Module	Module	High	Module	MAFS on Module / LPC enabled
5	0	0	0	SPI	Carrier	Module	PCH CS1#	Module	MAFS on Module / eSPI enabled
6	0	0	1	SPI	Module	Carrier	PCH CS0#	Carrier	MAFS on Carrier / eSPI enabled
7	0	1	0	eSPI	-	-	-	-	COMe-mAS10 (E2) does not support SAFS configurations (work like #5)
8	0	1	1	eSPI	-	-	-	-	



If ESPI_EN# selection of the carrier does not match the module configuration (eSPI/LPC) the module won't boot.

3.4.10. LPC/eSPI

The Low Pin Count (LPC) interface is pin shared with eSPI. A COM Express® module design may support either LPC or eSPI or both.

As LPC isn't provided by the processor platform an eSPI-to-LPC bridge is implemented on the COMe-mAS10 (E2) per default.

ESPI_EN# is available for the carrier to signal to the module whether LPC or eSPI is to be used.

- If ESPI_EN# is unconnected on the carrier, LPC operation is expected.
- For eSPI operation ESPI_EN# has to be connected to GND on the carrier.

To be able to detect the correct mode of operation, the module uses a pull-up resistor on this signal.



The module will not boot up if module and carrier configuration do not match.

Table 18: LPC/eSPI mode comparison

COMe Connector Pin	LPC mode (Embedded Controller)	eSPI mode (PCH)
LPC_AD[0:3]/ESPI_IO_[0:3]	LAD[0:3]	ESPI_IO_[0:3]
LPC_FRAME#/ESPI_CS0#	LFRAME#	ESPI_CS0#
LPC_CLK/ESPI_CLK	LPC_CLK0	ESPI_CLK
LPC_DRQ[0:1]#/ESPI_ALERT[0:1]#	LPC_DRQ[0:1]	ESPI_ALERT[0:1]#
LPC_SERIRQ/ESPI_CS1#	SER_IRQ	ESPI_CS1#
SUS_STAT#/ESPI_RESET#	SUS_STAT#	ESPI_RESET#
ESPI_EN#	ESPI_EN#	



For eSPI usage a HW modification and customized BIOS according to the customer's requirements is necessary. For further help on this please contact [JUMPTec Support](#).

3.4.11. I2C

The I2C buses are managed by the onboard Embedded Controller.

The external I2C bus transfers data between I2C devices connected on the bus, a further internal one between components on the module itself.

The Fast I2C bus transfers data with rates up to 400 kHz. To change the I2C bus speed in the BIOS setup menu select: **Advanced>Miscellaneous>I2C Speed> 1 kHz to 400 kHz**

The default speed is 200 kHz.

External user-accessible I2C (I2C_EXT)

The following table specifies the devices connected to the accessible I2C bus including the I2C address. This I2C bus is available at COMe connector pins I2C_CK, I2C_DAT.

Table 19: I2C Bus Port Address (I2C_EXT)

8-bit address	7-bit address	Device
0xA0	0x50	Module Embedded EEPROM (JIDA EEPROM)
0xAE	0x57	Carrier EEPROM (optional)

Internal I2C (I2C_INT)

The second I2C bus is primarily used for configuration of onboard devices, such as the LVDS bridge, but also for an external LVDS EEPROM.

3.4.12. GPIO

The COMe-mAS10 (E2) offers eight GPIOs, generated by the onboard embedded controller.

The type of termination resistor used defines the direction of the GPIO; GPIs are terminated by pull-up resistors, and GPOs are terminated by pull-down resistors.

Due to the fact that both the pull-up and pull-down termination resistors are weak, it is possible to override the termination resistors using external pull-ups, pull-downs or IOs. Overriding the termination resistors means that the eight GPIO pins can be considered as bi-directional since there are no restrictions whether you use the available GPIO pins in the in- or out-direction.

Configuration can be adjusted by the OS driver.

3.4.13. SMB

The System Management Bus (SMBus) is a simple 2-wire bus for low-speed system management communication. The (On-Package) PCH controls the SMBus. It is not used onboard on the module, but routed to the COMe connector.

The SMBus address uses the LSB (Bit 0) for the direction of the device.

Bit0 = 0 defines the write address

Bit0 = 1 defines the read address

3.4.14. MIPI-CSI

Two MIPI-CSI interfaces are available on request. The interfaces are made available via 2 additional connectors on the top side of the module.

Table 20: MIPI-CSI Port 0

MIPI CSI Connector Pin	MIPI CSI Pin Name	Processor
4/5, 7/8, 10/11, 13/14	CSI0_RX[0:3]±	CSI_B_DP/N[0:3]
16/17	CSI0_CK±	CSI_B_CLK_P/N
19	I2C_CAM0_CK	GPP_H7
20	I2C_CAM0_DAT	GPP_H6
21	CAMx_PWR#	GPP_A21

12	CAMx_RST#	GPP_R6
22	CAM0_MC	GPP_H20/IMGCLKOUT1
1,2	CAM0_VCC	Connected to 3V3_S0
3, 6, 15, 18	GND	Connected to GND

Table 21: MIPI-CSI Port 1

MIPI CSI Connector Pin	MIPI CSI Pin Name	Processor
4/5, 7/8, 10/11, 13/14	CSI1_RX[0:3]±	CSI_C_DP/N[0:3]
16/17	CSI1_CK±	CSI_C_CLK_P/N
19	I2C_CAM1_CK	GPP_B17
20	I2C_CAM1_DAT	GPP_B16
21	CAM1_PWR#	GPP_A22
12	CAM1_RST#	GPP_R7
22	CAM1_MC	GPP_H21/IMGCLKOUT2
1,2	CAM1_VCC	Connected to 3V3_S0
3, 6, 15, 18	GND	Connected to GND



The MIPI-CSI ports have been tested as proof-of-concept with the camera module LI-IMX415-MIPI-081H and adapter card LI-FPC22-IPEX-ONX from Leopard Imaging.
For further information please contact [JUMPtec Support](#).

3.5. Features

3.5.1. ACPI Power States

ACPI enables the system to power down, save power when not required (suspend) and wake up when required (resume).

ACPI controls the power states S0-S5, where S0 has the highest priority and S5 the lowest priority.

Table 22: ACPI Power States Function

S0	Working state
S1	Sleep (typically not supported anymore)
S2	Deep Sleep (typically not supported anymore)
S3	Suspend-to-RAM
S4	Suspend-to-disk / Hibernate
S5	Soft-off state



Not all ACPI defined power states are available.
The COMe-mAS10 (E2) supports ACPI 6.0 and the power states S0, S3, S4, S5.



To power on from state S3, S4, S5 use: Power Button, Wake On LAN

3.5.2. Embedded Controller - Hardware Monitor

The Embedded Controller (EC) together with the Power Sequence Controller (PSC) provides a broad set of functionality:

- power sequencing control
- monitoring the module's processor temperature, power supply voltages V_IN_VAR, VCC_5V_SBY, VCC_RTC
- monitoring and configuring the on-board and external fans
- acting as hub or super-I/O for low speed interfaces such as UART, I2C/SMB, GP_SPI, GPIO
- supporting watchdog functions

The EC is accessible through the API in the Board Support Package.

3.5.3. Trusted Platform Module

The COMe-mAS10 (E2) supports the firmware TPM (fTPM) using the integrated TPM 2.0 capability of the Intel Platform Trusted Technology (Intel® PTT). On request a discrete TPM chip can be offered which is directly connected to the dedicated SPI interface from the PCH.

3.5.4. Watchdog

The COMe-mAS10 (E2) supports an independently programmable dual-stage software watchdog timer. The watchdog functionality is accessible through the API of the Embedded Controller (EC) in the related Board Support Package. The watchdog is able to generate IRQ (SWI), SMI and SCI dependent on the implementation.

Please find more information about the watchdog implementation in the according API user guide for the EC implementation.

Time-out event	Description
No action	Stage is off and will be skipped
Reset	Restarts the module and starts a new POST and operating system
NMI	A non-maskable interrupt (NMI) is a computer processor interrupt that cannot be ignored by standard interrupt masking techniques in the system. It is used typically to signal attention for non-recoverable hardware errors.
SMI	A system management interrupt (SMI) makes the processor entering the system management mode (SMM). As such, specific BIOS code handles the interrupt. The current BIOS handler for the watchdog SMI currently does nothing. For special requirements, contact JUMPtac Support .
SCI	A system control interrupt (SCI) is a OS-visible interrupt to be handled by the OS using AML code
Delay	Might be necessary when an operating system must be started and the time for the first trigger pulse must be extended.

The software watchdog functionality can be combined with enabling/disabling the activity of the COMe WDT watchdog signal pin.

Table 23: Watchdog signal on COMe connector

COMe	EC	Description
WDT - Pin B27	B6	Generated by Embedded Controller.

3.5.5. Real-Time Clock (RTC)

The RTC keeps track of the current time accurately. The RTC's low power consumption enables the RTC to continue operation and keep time using a lower secondary source of power while the primary source of power is switched off or unavailable.

The COMe-mAS10 (E2) supports typical RTC values of 3 V and less than 10 μ A. When powered by the main power supply on-module regulators generate the RTC voltage, to reduce RTC current draw.



The input range at VCC_RTC is 2.5 – 3.3V (the COM Express specification COM.0 R3.1 defines an input range of 2.0 – 3.3 V).



It is not recommended to run a system without a RTC battery on the carrier board. Even if the RTC battery is not required to keep the actual time and date when main power is off, a missing RTC battery will cause other side effects such as longer boot times. Intel processor environments are generally designed to rely on RTC battery voltage.

3.5.6. eMMC

As BOM option an eMMC (Embedded Multimedia Flash Card) can be populated on the COMe-mAS10 (E2). The eMMC is eMMC 5.1 compatible.

eMMCs are available as MLC = Multi-Level-Cell or TLC = Triple-Level-Cell.

In order to improve reliability, endurance and performance eMMCs can be re-configured as pSLCs = pseudo Single-Level-Cell.

eMMCs are available with a maximum capacity of 256GB as TLC.

Reconfiguring to pSLC reduces the eMMC capacity.

The standard COMe-mAS10 E2 variants support TLC eMMC.

On request, other eMMC capacities or configurations can be offered.



Pseudo SLC (pSLC) memory is a reconfigured MLC/TLC eMMC.

MLC to pSLC: the capacity is half of a MLC memory.

TLC to pSLC: the capacity is a third of the TLC memory.

3.5.7. Boot SPI Device

A 32 MByte SPI Flash device supporting SFDP (Serial Flash Discovery Parameter) is attached to the PCH FSPI interface (dedicated SPI interface from On-Package PCH for TPM and flash memory). Flash Descriptor, BIOS, converged security engine as well as platform data are stored within the SPI Flash. The SPI interface is routed to the COM Express connector (see [Chapter 3.4.9](#))

Following Flash Devices are supported by the BIOS:

Table 24: Supported SPI Flash Devices

Size	Manufacturer	Part Number	Package Type
32 MByte	Macronix	MX25L25645GZ2I-08G	WSON-8
32 MByte	Micron	MT25QL256ABA1EW9-0SIT	WSON-8
32 MByte	Winbond	W25Q256JVEIQ	WSON-8
32 MByte	Cypress	S25FL256LAGNFI010	WSON-8

3.5.8. Embedded EEPROM

The module's 32 kbit serial EEPROM (formerly known as JIDA EEPROM) device is attached to the I2C bus (I2C_EXT) from the Embedded Controller and accessible via I2C bus 8-bit address 0xA0 (see [Chapter 3.4.11](#))

3.5.9. Features on Request

For the COMe-mAS10 (E2) following optional features are available on request:

Table 25: Features on Request

Optional Features (on request)	
x7000E	CPU from x7000E processor series
LPDDR5	Memory down up to 16GB
eMMC 5.1	Up to 256GB eMMC 5.1 Flash TLC technology - configuration as pSLC can be offered
TPM	Discrete TPM 2.0 chip
eDP	Support of eDP instead of LVDS
eSPI	Instead of LPC signals, eSPI signals are routed to the according pins of the COMe connector
UART	2 UART serial RX/TX ports from SOC (PCIe based, non-legacy) instead of Embedded Controller
GP-SPI	Signals routed to SPI pins of COMe connector
MIPI-CSI	2x MIPI-CSI connectors

3.6. Electrical Specification

The module powers on by connecting to a carrier board via the COM-Express interface connectors.

The COM Express interface connector pins on the module limit the amount of power received.

CAUTION

Before connecting the module's interface connector to the carrier board's corresponding connector, ensure that the carrier board is switched off and disconnected from the main power supply. Failure to disconnect the main power supply could result in personal injury and damage to the module and/or carrier board.

CAUTION

Observe that only trained personnel aware of the associated dangers connect the module, within an access controlled ESD-safe workplace

3.6.1. Power Supply Specification

The power specification of the module supports a single supply voltage of 12 V and a wide input voltage range of 4.75 V to 20 V. Other supported voltages are 5 V standby and 3 V RTC battery input.

Table 23: Power Supply Specification

Supply Voltage range (VCC)	4.75 V to 20 V
Supply Voltage (VCC)	12 V \pm 5%
Standby Voltage (VCC_5V_SBY)	5 V \pm 5% - Note: Standby voltage is not mandatory for operation
RTC Voltage (VCC_RTC)	2.5 V to 3.3 V

CAUTION

Only connect to an external power supply delivering the specified input rating and complying with the requirements of Safety Extra Low Voltage (SELV) and Limited Power Source (LPS) of UL/IEC 60950-1 or (PS2) of UL/IEC 62368-1.



To protect external power lines of peripheral devices, make sure that the wires have the right diameter to withstand the maximum available current and the enclosure of the peripheral device fulfils the fire-protection requirements of IEC/EN 62368-1.



If any of the supply voltages drops below the allowed operating level longer than the specified hold-up time, all the supply voltages should be shut down and left OFF for a time long enough to allow the internal board voltages to discharge sufficiently. If the OFF time is not observed, parts of the board or attached peripherals may work incorrectly or even suffer a reduction of MTBF. The minimum OFF time depends on the implemented PSU model and other electrical factors and must be measured individually for each case.

3.6.1.1. Power Supply Voltage Rise Time

The input voltage rise time is 0.1 ms to 20 ms from input voltage $\leq 10\%$ to nominal input voltage. To comply with the ATX specification there must be a smooth and continuous ramp of each DC input voltage from 10 % to 90 % of the DC input voltage final set point.

3.6.1.2. Power Supply Voltage Ripple

The maximum power supply voltage ripple and noise is 100 mV peak-to-peak measured over a frequency bandwidth of 0 MHz to 20 MHz. The voltage ripple, must not cause the input voltage range to be exceeded.

3.6.1.3. Power Supply Inrush Current

The maximum inrush current at 5 V standby is 2 A. From states G3 (module is mechanically completely off, with no power consumption) or S5 (module appears to be completely off) to state S0 (module is fully usable) the maximum inrush current meets the SFX Design Guide.

3.6.2. Power Management

The Advanced Configuration and Power Interface (ACPI) 5.0 hardware specification supports features such as power button and suspend states. The power management options are available within the BIOS set up menu: **Advanced>ACPI Settings>**

3.6.2.1. Suspend States

If power is removed, 5V can be applied to the V_5V_SBY pins to support the ACPI suspend-states:

- Suspend to RAM (S3)
- Suspend to Disk (S4)
- Soft-off (S5)



If power is removed, the wake-up event (S0) requires 12V VCC to power on the module for normal operation.

3.6.2.2. Power Supply Control Signals

Power supply control settings are set in the BIOS and enable the module to shut down, reset and wake from standby.

Table 26: Power Supply Control Signals

COMe Signal	Pin	Description
Power Button (PWRBTN#)	B12	A PWRBTN# falling edge signal creates power button event ($50\text{ ms} \leq t < 4\text{ s}$, typical 400 ms) at low level. Power button events can be used to bring a system out of S5 soft-off and other suspend states, as well as powering the system down. Pressing the power button for at least four seconds turns off power to the module Power Button Override.
Power Good (VIN_PWR_OK)	B24	Indicates that all power supplies to the module are stable within specified ranges. PWR_OK signal goes active and module internal power supplies are enabled. PWR_OK can be driven low to prevent module from powering up until the carrier is ready and releases the signal. PWR_OK should not be deactivated after the module enters S0 unless there is a power fail condition.
Reset Button (SYS_RESET#)	B49	When the SYS_RESET# pin is detected active (falling edge triggered), it allows the processor to perform a “graceful” reset, by waiting up to 25 ms for the SMBus to enter the idle state before forcing a reset, even though activity is still occurring. Once reset is asserted, it remains asserted for 5 ms to 6 ms regardless of whether the SYS_RESET# input remains asserted or not.
Carrier Board Reset (CB_Reset#)	B50	When CB_Reset# from module to carrier is active low, the module outputs a request to the carrier board to reset.
SMBus Alert (SMB_ALERT#)	B15	System Management Bus Alert – active low input can be used to generate an SMI# (System Management Interrupt) or to wake the system. It may be useful for implementation on the Carrier Board of standards such as Smart Battery. When an external battery manager is present and SMB_ALERT# connected, the module powers on even if the BIOS switch “After Power Fail” is set to “Stay Off”.
Battery Low (BATLOW#)	A11	BATLOW# indicates that the external battery is low and provides a batterylow signal to the module for orderly transitioning to power saving or power cut-off ACPI modes
PCIe Wake UP (WAKE0#)	B66	PCI Express wake up signal.
GP Wake UP (WAKE1#)	B67	General purpose wake up signal. May be used to implement wake-up on PS2 keyboard or mouse activity.
Suspend Control (SUS_STAT#)	B18	SUS_STAT# indicates an imminent suspend operation. Used to notify LPC devices.
Suspend to RAM (SUS_S3#)	A15	Indicates system is in Suspend-to-RAM state. Active low output.
Suspend to Disk (SUS_S4#)	A18	Indicates system is in Suspend-to-disk state. Active low output.
Soft-off (SUS_S5#)	A24	Indicates system is in Soft-off state. Active low output.
Lid detection (LID#)	A103	LID switch: Low active signal used by the ACPI operating system for a LID switch.
Sleep button (SLEEP#)	B103	Sleep button: Low active signal used by the ACPI operating system to bring the system to sleep state or to wake it up again.

3.6.3. Power Supply Modes

The COMe-mAS10 (E2) is operating in either ATX power mode or single power supply mode.

3.6.3.1. ATX Power Supply Mode

To start the module in ATX mode, connect VCC and 5V Standby from a ATX PSU. As soon as the standby rail ramps up the PCH enters the S5 state and starts the transition to S0. SUS_S3# (usually connected to PSU PS_ON#) turns on the main power rail (VCC). As soon as the PSU indicates that the power supply is stable (PWR_OK high) the PCH continues the transition to S0.



The input voltage must always be higher than 5 V standby (VCC>5VSB) for modules supporting a wide input voltage range down to 4.75 V.

Table 27: ATX Mode Settings

State	PWRBTN#	PWR_OK	V5_Standby	PS_ON#	VCC
G3	X[1]	X[1]	0V	X[1]	0V
S5	high	low	5V	high	0V
S5 → S0	PWRBTN Event	low → high	5V	high →	0V → VCC
S0	high	high	5V	low	VCC

[1] Defines that there is no difference if connected or open.

3.6.3.2. Single Power Supply Mode

To start the module in single power supply mode, connect VCC power and open PWR-OK at the high level. VCC can be 4.75 V to 20 V. To power on the module from S5 state, press the power button or reconnect VCC.

Table 28: Single Power Supply Mode Settings

State	PWRBTN#	PWR_OK	V5_Standby	VCC
G3	0V/X[1]	0V/ X[1]	0V/ X[1]	0V/ X[1]
G3 → S0	high	open/high	open	VCC
S0 → S5	PWRBTN or Sleep Event	open/high	open	VCC
S5 → S0	PWRBTN or Wake Event	open/high	open	VCC
S0 → G3	0V/ X[1]	0V/ X[1]	0V/ X[1]	0V/ X[1]

[1] Defines that there is no difference if connected or open.



All ground pins must be connected to the carrier board's ground plane.

3.7. Thermal Management

3.7.1. Heatspreader Plate Assembly

A heatspreader plate assembly is available from JUMPTec for the COMe-mAS10 (E2).

The heatspreader plate assembly is NOT a heat sink. The heatspreader plate transfers heat as quickly as possible from the processor using a copper core positioned directly above the processor and a Thermal Interface Material (TIM). The heatspreader plate is factory prepared with a TIM screen printed on the contacts and may be fasten to the module without additional user actions.

The heatspreader plate works as a COM Express standard thermal interface and must be used with a heat sink or external cooling devices to maintain the heatspreader plate at proper operating temperatures.

Under worst-case conditions, the cooling mechanism must maintain an ambient air and heatspreader plate temperature on any spot of the heatspreader's surface according the module's specification:

- 60°C for commercial temperature grade modules
- 75°C for extended temperature grade modules (E1)
- 85°C for industrial temperature grade modules (E2)

3.7.2. Active/Passive Cooling Solutions

Both active and passive thermal management approaches can be used with the heatspreader plate. The optimum cooling solution depends on the application and environmental conditions. JUMPtec's active or passive cooling solutions are designed to cover the power and thermal dissipation for a commercial temperature range used in housing with a suitable airflow.

3.7.3. Operating with Heatspreader Plate (HSP) Assembly

The operating temperature requirements are:

- Maximum ambient temperature with ambient being the air surrounding the module
- Maximum measurable temperature on any part on the heatspreader's surface

Table 29: Heatspreader Temperature Specification

Temperature Grade	Requirements
Commercial Grade	at 60°C HSP temperature on MCP @ 100% load; needs to run at nominal frequency
Extended Grade(E1)	at 75°C HSP temperature the MCP @ 75% load; is allowed to start throttling for thermal protection
Industrial Grade (E2)	at 85°C HSP temperature the MCP @ 50% load; is allowed to start throttling for thermal protection

3.7.4. Operating without Heatspreader Plate (HSP) Assembly

The operating temperature is the maximum measurable temperature on any spot of the module's surface.

3.7.5. Temperature Sensors

The modules's processor is capable of reading its internal temperature. The embedded controller EC (uses an on-chip temperature sensor to measure the module's temperature on the board.

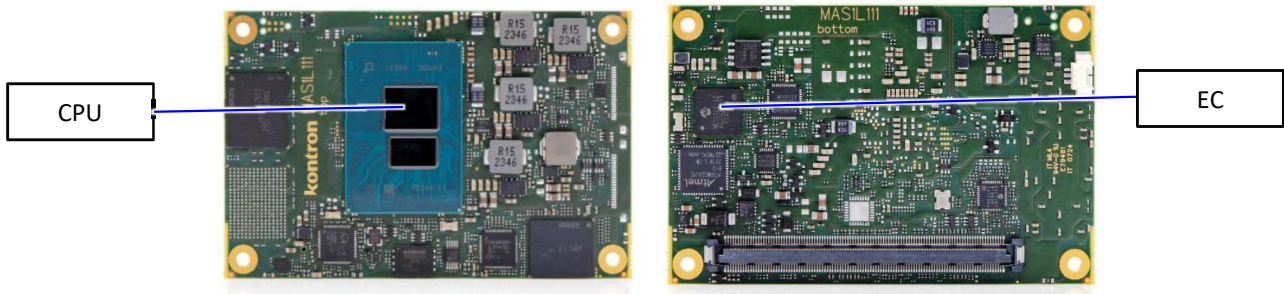

Figure 4: Module Temperature Sensors

3.7.6. On-Module Fan Connector

The module's fan connector powers, controls and monitors an external fan. To connect a standard 3-pin connector fan to the module, use JUMPtec's fan cables:

- KAB-HSP 200 mm (96079-0000-00-0)
- KAB-HSP 400 mm (96079-0000-00-2)

Position of the fan connector see [Chapter 3.3.4](#)

The analog output voltage on this connector is generated via a discrete linear voltage regulator from the PWM signal of the HWM. It is clipped at 12 V (+/- 10 %) across the whole input range of the module to prevent fan damage at higher voltages.

The maximum supply current to the fan is 350 mA if the input voltage is below 13 V and is further limited to 150 mA if the input voltage to the module is between 13 V and 20 V.

Table 30: Fan Connector (3-Pin) Pin Assignment

Pin	Signal	Description	Type
1	Fan_Tach_IN#	Fan input voltage from COMe connector	Input
2	V_FAN	12 V \pm 10% (max.) across module input range	PWR
3	GND	Power GND	PWR

NOTICE

Always check the fan specification according to the limitations of the supply current and supply voltage.

3.8. Mechanical Specification

3.8.1. Module Dimensions

The COMe mini module dimensions are 84 mm x 55 mm (3.3" x 2.17").

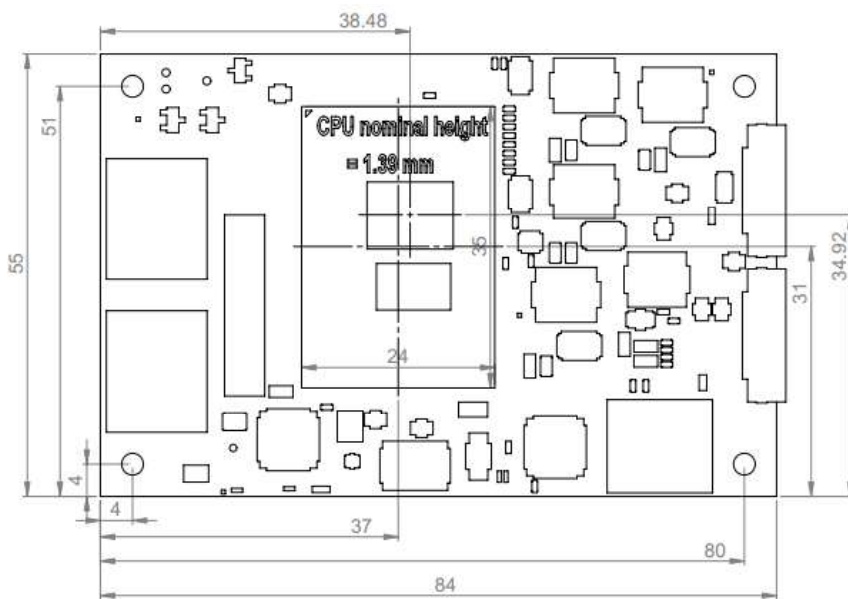
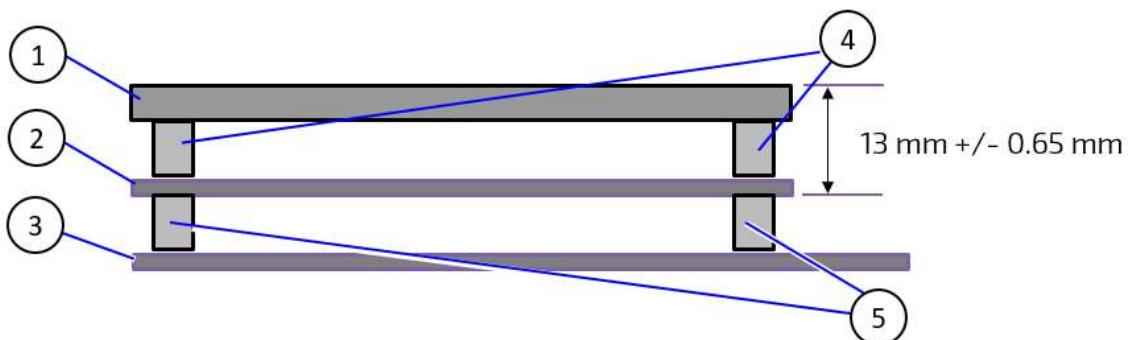

Figure 5: Module Dimensions

3.8.2. Module Height

The COM Express® specification defines a module height of approximately 13mm, when measured from the bottom of the module's PCB board to the top of the heatspreader. The overall height of the module and carrier board depends on:

- which carrier board connectors are used (5mm and 8mm height are available)
- which cooling solution is used. The height of the cooling solution is not specified in the COM Express specification



- | | | | |
|---|-------------------|---|------------------------------------|
| 1 | Heatspreader | 4 | Heatspreader standoff(s) |
| 2 | Module PCB board | 5 | Connector standoff(s) 5 mm or 8 mm |
| 3 | Carrier PCB board | | |

Figure 6: Module and Carrier Height with 5 and 8mm connector height

3.8.3. Heatspreader Plate Assembly Dimension

Please check our [Customer Section](#) for Heatspreader 3D models and drawings

3.9. Environmental Specification

The COMe-mAS10 (E2) supports commercial and industrial temperature grades.

Table 31: Environmental Specification

Environmental		Description
Commercial Grade	Operating	0°C to +60°C (32°F to 140°F)
	Non-operating	-30°C to +85°C (-22°F to 185°F)
Industrial Grade (E2)	Operating	-40°C to +85°C (-40°F to 185°F)
	Non-operating	-40°C to +85°C (-40°F to 185°F)
Relative Humidity		93 % @40°C, non-condensing
Shock (according to IEC / EN 60068-2-27)		Non-operating shock test (half-sinusoidal, 11ms, 15g)
Vibration (according to IEC / EN 60068-2-6)		Non-operating vibration (sinusoidal, 10 Hz to 2000 Hz, +/- 0.15 mm, 2 g)

3.10. Compliance

The COMe-mAS10 (E2) complies with the following or the latest status thereof. If modified, the prerequisites for specific approvals may no longer apply. For more information, contact [JUMPtec Support](#).

Table 32: Compliance CE Mark

Europe - CE Mark	
Directives	2014/30/EU: Electromagnetic Compatibility 2014/35/EU: Low Voltage 2011/65/EU: RoHS II 2001/95/EC: General Product Safety
EMC	EN 55032 Class B: Electromagnetic compatibility of multimedia equipment - Emission Requirements Class A EN 61000-6-2: Electromagnetic compatibility (EMC) Part 6-2: Generic standards - Immunity standard for industrial environments
Safety	EN 62368-1: Audio/video, information and communication technology equipment - Part 1: Safety requirements

Table 33: Country Compliance

USA/Canada	
Safety	UL 62368-1 & CSA C22.2 No. 62368-1 (Component Recognition): Audio/video, information and communication technology equipment - Part 1: Safety requirements Recognized by Underwriters Laboratories Inc. Representative samples of this component have been evaluated by UL and meet applicable UL requirements. UL listings: AZOT2.E547070 AZOT8.E547070
UK CA Mark	
EMC	BS EN 55032 Class B: Electromagnetic compatibility of multimedia equipment - Emission Requirements Class A BS EN 61000-6-2: Electromagnetic compatibility (EMC) Part 6-2: Generic standards - Immunity standard for industrial environments

Safety	BS EN 62368-1: Audio/video, information and communication technology equipment - Part 1: Safety requirements
CB scheme (for international certifications)	
Safety	IEC 62368-1: Audio/video, information and communication technology equipment - Part 1: Safety requirements



If the product is modified, the prerequisites for specific approvals may no longer apply.



JUMPTec is not responsible for any radio television interference caused by unauthorized modifications of the delivered product or the substitution or attachment of connecting cables and equipment other than those specified by JUMPTec. The correction of interference caused by unauthorized modification, substitution or attachment is the user's responsibility.

3.11. MTBF

The MTBF (Mean Time Before Failure) values were calculated using a combination of the manufacturer's test data (if available) and the Telcordia (Bellcore) issue 2 calculation for the remaining parts.

The Telcordia calculation used is "Method 1 Case 3" in a ground benign, controlled environment. This particular method takes into account varying temperature and stress data and the system is assumed to have not been burned-in. Other environmental stresses (such as extreme altitude, vibration, saltwater exposure) lower MTBF values.

MTBF (hours @40°C)	Part Number
875350	34017-1632-R2-8

Table 34: MTBF



The MTBF estimated value above assumes no fan, but a passive heat sinking arrangement. Estimated RTC battery life (as opposed to battery failures) is not accounted for and needs to be considered separately. Battery life depends on both temperature and operating conditions. When the module is connected to external power, the only battery drain is from leakage paths.

4/COMe Interface Connector

The COME-mAS10 (E2) is a COM Express® Type 10 module providing one 220-pin connector J1 with two rows called row A & B.

Position of the connector see [Chapter 3.3.4](#).

4.1. Connecting COMe Interface Connector to Carrier Board

The COMe interface connector (J1) is inserted into the corresponding connector on the carrier board and secured using the mounting points and standoffs. The height of the standoffs (either 5 mm or 8 mm) depends on the height of the carrier board's connector.

⚠ CAUTION

The module is powered on by connecting to the carrier board using the interface connector. Before connecting the module's interface connector to the carrier board's corresponding connector, ensure that the carrier board is switch off and disconnected from the main power supply. Failure to disconnect the main power supply could result in personal injury and damage to the module and/or carrier board. Observe that only trained personnel aware of the associated dangers connect the module, within an access controlled ESD-safe workplace.



To protect external power lines of peripheral devices, make sure that the wires have the right diameter to withstand the maximum available current. The enclosure of the peripheral device fulfills the fire-protection requirements of IEC/EN 62368.

4.2. J1 Signals

For a description of the terms used in the J1 pin assignment tables, see table given below. If a more detailed pin assignment description is required, refer to PICMG® COM.0 Revision 3.1 Base Specification.

Table 35: General Signal Description

Type	Description	Type	Description
NC	Not Connected (on this product)	O-1.8	1.8 V Output
I/O-3.3	Bi-directional 3.3 V I/O-Signal	O-3.3	3.3 V Output
I/O-5T	Bi-dir. 3.3 V I/O (5 V tolerance)	O-5	5 V Output
I/O-5	Bi-directional 5V I/O-Signal	DP-I/O	Differential Pair Input/Output
I-3.3	3.3 V Input	DP-I	Differential Pair Input
I/OD	Bi-directional Input/Output Open Drain	DP-O	Differential Pair Output
I-5T	3.3 V Input (5 V tolerance)	PU/PD	Pull-Up/Pull-Down Resistor
OA	Output Analog	PWR	Power Connection
OD	Output Open Drain	+/-	Differential Pair Differentiator



The pin assignment tables list the internal pull-ups (PU) or pull-downs (PD) implemented by the chip vendors.

4.3. Connector J1

4.3.1. Pins A1 - A110

Table 36: Connector J1 Pins A1 - A110 according to COM-0 Rev 3.1

Pin	Signal	Description	Type	Termination	Comment
A1	GND	Power Ground	PWR GND	---	---
A2	GBE0_MDI3-	Ethernet Media Dependent Interface 3 -	DP-I/O	---	---
A3	GBE0_MDI3+	Ethernet Media Dependent Interface 3 +	DP-I/O	---	---
A4	GBE0_LINK_MID#	Ethernet Speed LED	OD	---	---
A5	GBE0_LINK_MAX#	Ethernet Speed LED	OD	---	---
A6	GBE0_MDI2-	Ethernet Media Dependent Interface 2 -	DP-I/O	---	---
A7	GBE0_MDI2+	Ethernet Media Dependent Interface 2 +	DP-I/O	---	---
A8	GBE0_LINK#	LAN Link LED	OD	---	---
A9	GBE0_MDI1-	Ethernet Media Dependent Interface 1 -	DP-I/O	---	---
A10	GBE0_MDI1+	Ethernet Media Dependent Interface 1 +	DP-I/O	---	---
A11	GND	Power Ground	PWR GND	---	---
A12	GBE0_MDI0-	Ethernet Media Dependent Interface 0 -	DP-I/O	---	---
A13	GBE0_MDI0+	Ethernet Media Dependent Interface 0 +	DP-I/O	---	---
A14	GBE0_CTREF	Center Tab Reference Voltage	O	---	100nF capacitor to GND
A15	SUS_S3#	Suspend To RAM (or deeper) Indicator	O-3.3	PD 100K	---
A16	SATA0_TX+	SATA Transmit Pair 0 +	DP-O	AC coupled on module (10nF)	---
A17	SATA0_TX-	SATA Transmit Pair 0 -	DP-O	AC coupled on module (10nF)	---
A18	SUS_S4#	Suspend To Disk (or deeper) Indicator	O-3.3	PD 100K	---
A19	SATA0_RX+	SATA Receive Pair 0 +	DP-I	AC coupled on module (10nF)	---
A20	SATA0_RX-	SATA Receive Pair 0 -	DP-I	AC coupled on module (10nF)	---
A21	GND	Power Ground	PWR GND	---	---
A22	USB_SSRX0-	USB Super Speed Receive 0 -	DP-I	---	---
A23	USB_SSRX0+	USB Super Speed Receive 0 +	DP-I	---	---
A24	SUS_S5#	Soft Off Indicator	O-3.3	PD 100K	---
A25	USB_SSRX1-	USB Super Speed Receive 1 -	DP-I	---	---
A26	USB_SSRX1+	USB Super Speed Receive 1 +	DP-I	---	---
A27	BATLOW#	Battery Low	I-3.3	PU 10K (S5)	assertion will prevent wake from S3-S5 state
A28	(S)ATA_ACT#	Serial ATA activity LED	OD-3.3	PU 10K (S0)	SPKR / SATA_LED# share the same PCH IO selectable via setup option (default SATA_LED#)
A29	HDA_SYNC	HD Audio Sync	O-3.3	---	on module 27ohm series termination
A30	HDA_RST#	HD Audio Reset	O-3.3	PD 100K	on module 27ohm series termination
A31	GND	Power Ground	PWR GND	---	---

Pin	Signal	Description	Type	Termination	Comment
A32	HDA_CLK	HD Audio Bit Clock Output	O-3.3	PD 100K	on module 27ohm series termination
A33	HDA_SDOUT	HD Audio Serial Data Out	O-3.3	---	on module 27ohm series termination
A34	BIOS_DIS0#/ESPI_SAFS	BIOS Selection Strap 0	I-3.3	PU 10K (S5)	---
A35	THRMTRIP#	Thermal Trip	O33-OD	PU 10K (S0)	Thermal Trip Event, transition to S5 indicator
A36	USB6-	USB 2.0 Data Pair Port 6 -	DP-I/O	PD 14.25K to 24.8K in PCH	---
A37	USB6+	USB 2.0 Data Pair Port 6 +	DP-I/O	PD 14.25K to 24.8K in PCH	---
A38	USB_6_7_OC#	USB Overcurrent Indicator Port 6/7	I-3.3	PU 10K (S5)	---
A39	USB4-	USB 2.0 Data Pair Port 4 -	DP-I/O	PD 14.25K to 24.8K in PCH	---
A40	USB4+	USB 2.0 Data Pair Port 4 +	DP-I/O	PD 14.25K to 24.8K in PCH	---
A41	GND	Power Ground	PWR GND	---	---
A42	USB2-	USB 2.0 Data Pair Port 2 -	DP-I/O	PD 14.25K to 24.8K in PCH	---
A43	USB2+	USB 2.0 Data Pair Port 2 +	DP-I/O	PD 14.25K to 24.8K in PCH	---
A44	USB_2_3_OC#	USB Overcurrent Indicator Port 2/3	I-3.3	PU 10K (S5)	---
A45	USB0-	USB 2.0 Data Pair Port 0 -	DP-I/O	PD 14.25K to 24.8K in PCH	---
A46	USB0+	USB 2.0 Data Pair Port 0 +	DP-I/O	PD 14.25K to 24.8K in PCH	---
A47	VCC_RTC	Real-Time Clock Circuit Power Input	PWR 3V	---	voltage range 2.3-5.5V
A48	RSMRST_OUT#	Resume Reset Out	O-3.3	---	---
A49	GBE0_SDP	Gigabit Ethernet Controller 0 Software-Definable Pin	I/O-3.3	---	---
A50	LPC_SERIRQ / ESPI_CS1#	Serial Interrupt Request / eSPI Master Chip Select 1	IO33-OD / O-1.8	PU 8K2 3.3V (S0) / PU 10K 1.8V (S5)	LPC only
A51	GND	Power Ground	PWR GND	---	---
A52	RSVD	Reserved for future use	nc	---	---
A53	RSVD	Reserved for future use	nc	---	---
A54	GPI0	General Purpose Input 0	I-3.3	PU 100K (S0)	---
A55	GP_SPI_CS#	General Purpose SPI Chip Select	O-3.3	---	---
A56	GP_SPI_CK	General Purpose SPI Clock	O-3.3	---	on module 33ohm series termination
A57	GND	Power Ground	PWR GND	---	---
A58	PCIE_TX3+	PCI Express Lane 3 Transmit +	DP-O	AC coupled on module (220nF)	---
A59	PCIE_TX3-	PCI Express Lane 3 Transmit -	DP-O	AC coupled on module (220nF)	---
A60	GND	Power Ground	PWR GND	---	---
A61	PCIE_TX2+	PCI Express Lane 2 Transmit +	DP-O	AC coupled on module (220nF)	---
A62	PCIE_TX2-	PCI Express Lane 2 Transmit -	DP-O	AC coupled on module (220nF)	---
A63	GPI1	General Purpose Input 1	I-3.3	PU 100K (S0)	---
A64	PCIE_TX1+	PCI Express Lane 1 Transmit +	DP-O	AC coupled on module (220nF)	---
A65	PCIE_TX1-	PCI Express Lane 1 Transmit -	DP-O	AC coupled on module (220nF)	---
A66	GND	Power Ground	PWR GND	---	---
A67	GPI2	General Purpose Input 2	I-3.3	PU 100K (S0)	---

Pin	Signal	Description	Type	Termination	Comment
A68	PCIE_TX0+	PCI Express Lane 0 Transmit +	DP-O	AC coupled on module (220nF)	---
A69	PCIE_TX0-	PCI Express Lane 0 Transmit -	DP-O	AC coupled on module (220nF)	---
A70	GND	Power Ground	PWR GND	---	---
A71	LVDS_A0+	LVDS Channel A DAT0+ / EDP Lane 2 Transmit +	DP-O	---	LVDS/eDP selectable via HW BOM option
A72	LVDS_A0-	LVDS Channel A DAT0- / EDP Lane 2 Transmit -	DP-O	---	LVDS/eDP selectable via HW BOM option
A73	LVDS_A1+	LVDS Channel A DAT1+ / EDP Lane 1 Transmit +	DP-O	---	LVDS/eDP selectable via HW BOM option
A74	LVDS_A1-	LVDS Channel A DAT1- / EDP Lane 1 Transmit -	DP-O	---	LVDS/eDP selectable via HW BOM option
A75	LVDS_A2+	LVDS Channel A DAT2+ / EDP Lane 0 Transmit +	DP-O	---	LVDS/eDP selectable via HW BOM option
A76	LVDS_A2-	LVDS Channel A DAT2- / EDP Lane 0 Transmit -	DP-O	---	LVDS/eDP selectable via HW BOM option
A77	LVDS_VDD_EN	LVDS / EDP Panel Power Control	O-3.3	PD 100K	LVDS/eDP selectable via HW BOM option
A78	LVDS_A3+	LVDS Channel A DAT3+	DP-O	---	---
A79	LVDS_A3-	LVDS Channel A DAT3-	DP-O	---	---
A80	GND	Power Ground	PWR GND	---	---
A81	LVDS_A_CK+	LVDS Channel A Clock+ / EDP Lane 3 Transmit +	DP-O	---	LVDS clock: 20-80MHz / LVDS/eDP selectable via HW BOM option
A82	LVDS_A_CK-	LVDS Channel A Clock- / EDP Lane 3 Transmit -	DP-O	---	LVDS clock: 20-80MHz / LVDS/eDP selectable via HW BOM option
A83	LVDS_I2C_CK	LVDS I2C Clock (DDC) / EDP AUX +	I/O-3.3 / DP-O	PU 3K9 (S0)	LVDS/eDP selectable via HW BOM option
A84	LVDS_I2C_DAT	LVDS I2C Data (DDC) / EDP AUX -	I/O-3.3 / DP-O	PU 3K9 (S0)	LVDS/eDP selectable via HW BOM option
A85	GPI3	General Purpose Input 3	I-3.3	PU 100K (S0)	---
A86	RSVD	Reserved for future use	nc	---	---
A87	EDP_HPD	EDP Hot Plug Detect	I-3.3	PD 400K	---
A88	PCIE_CLK_REF+	Reference PCI Express Clock +	DP-O	---	f = 100MHz
A89	PCIE_CLK_REF-	Reference PCI Express Clock -	DP-O	---	
A90	GND	Power Ground	PWR GND	---	---
A91	SPI_POWER	3.3V Power Output Pin for external SPI flash	O-3.3	---	I _{out} = 100mA (max.)
A92	SPI_MISO	SPI Master IN Slave OUT	I-3.3	---	---
A93	GPO0	General Purpose Output 0	O-3.3	PD 100K	---
A94	SPI_CLK	SPI Clock	O-3.3	PD 100K	---
A95	SPI_MOSI	SPI Master Out Slave In	O-3.3	---	---
A96	TPM_PP	TPM Physical Presence	I-3.3	PD 10K	used TPM does not support this functionality
A97	TYPE10#	Indicates TYPE10# to carrier board	PDS	PD 10K	---
A98	SERO_TX	Serial Port 0 TXD	O-3.3	---	20V protection circuit implemented on module; PD on carrier board needed for proper operation
A99	SERO_RX	Serial Port 0 RXD	I-5T	PU 10K 3.3V (S0)	20V protection circuit implemented on module
A100	GND	Power Ground	PWR GND	---	---
A101	SER1_TX	Serial Port 1 TXD	O-3.3	---	20V protection circuit implemented on module; PD on carrier board needed for proper operation

Pin	Signal	Description	Type	Termination	Comment
A102	SER1_RX	Serial Port 1 RXD	I-5T	PU 10K 3.3V (S0)	20V protection circuit implemented on module
A103	LID#	LID Switch Input	I-3.3	PU 47K (S5)	20V protection circuit implemented on module
A104	VCC_12V	Main Input Voltage (4.75-20V)	PWR	---	---
A105	VCC_12V	Main Input Voltage (4.75-20V)	PWR	---	---
A106	VCC_12V	Main Input Voltage (4.75-20V)	PWR	---	---
A107	VCC_12V	Main Input Voltage (4.75-20V)	PWR	---	---
A108	VCC_12V	Main Input Voltage (4.75-20V)	PWR	---	---
A109	VCC_12V	Main Input Voltage (4.75-20V)	PWR	---	---
A110	GND	Power Ground	PWR GND	---	---

4.3.2. Pins B1 - B110

Table 37: Connector J1 Pins B1 - B110 according to COM-0 Rev 3.1

Pin	Signal	Description	Type	Termination	Comment
B1	GND	Power Ground	PWR GND	---	---
B2	GBE0_ACT#	Ethernet Activity LED	OD	---	---
B3	LPC_FRAME#/ ESPI_CS0	LPC Frame Indicator / eSPI Master Chip Select 0	O-3.3 / O-1.8	---	---
B4	LPC_AD0/ ESPI_IO_0	LPC Multiplexed Command, Address & Data 0 / eSPI Master Data I/O 0	I/O-3.3 / I/O-1.8	PU 20K 3.3V (S0) / -	LPC/eSPI selectable via HW BOM option (LPC by default)
B5	LPC_AD1/ ESPI_IO_1	LPC Multiplexed Command, Address & Data 1 / eSPI Master Data I/O 1	I/O-3.3 / I/O-1.8	PU 20K 3.3V (S0) / -	LPC/eSPI selectable via HW BOM option (LPC by default)
B6	LPC_AD2/ ESPI_IO_2	LPC Multiplexed Command, Address & Data 2 / eSPI Master Data I/O 2	I/O-3.3 / I/O-1.8	PU 20K 3.3V (S0) / -	LPC/eSPI selectable via HW BOM option (LPC by default)
B7	LPC_AD3/ ESPI_IO_3	LPC Multiplexed Command, Address & Data 3 / eSPI Master Data I/O 3	I/O-3.3 / I/O-1.8	PU 20K 3.3V (S0) / -	LPC/eSPI selectable via HW BOM option (LPC by default)
B8	LPC_DRQ0#/ ESPI_ALERT0#	LPC Serial DMA Request 0 / eSPI Alert 0	I-3.3 I-1.8	PU 10K (S0) / -	LPC DMA Request not supported LPC/eSPI selectable via HW BOM option
B9	LPC_DRQ1#/ ESPI_ALERT1#	LPC Serial DMA Request 1 / eSPI Alert 1	I-3.3 I-1.8	PU 10K (S0) / -	LPC DMA Request not supported LPC/eSPI selectable via HW BOM option
B10	LPC_CLK/ ESPI_CK	LPC clock / eSPI clock	O-3.3 / O-1.8	---	f_LPC = 24MHz / f_eSPI = 50MHz max. (depends on attached slaves capabilities)
B11	GND	Power Ground	PWR GND	---	---
B12	PWRBTN#	Power Button	I-3.3	PU 10K (S5)	---
B13	SMB_CLK	SMBUS Clock	O-3.3	PU 3K9 (S5)	---
B14	SMB_DAT	SMBUS Data	I/O-3.3	PU 3K9 (S5)	---
B15	SMB_ALERT#	SMBUS Alert	I-3.3	PU 10K (S5)	---
B16	SATA1_TX+	SATA 1 Transmit Pair +	DP-O	AC coupled on module (10nF)	---
B17	SATA1_TX-	SATA 1 Transmit Pair -	DP-O	AC coupled on module (10nF)	---
B18	SUS_STAT#/ ESPI_RESET#	Suspend Status / eSPI Reset	O-3.3 / O-1.8	PD 10K / PD 75K	---
B19	SATA1_RX+	SATA 1 Receive Pair +	DP-I	AC coupled on module (10nF)	---
B20	SATA1_RX-	SATA 1 Receive Pair -	DP-I	AC coupled on module (10nF)	---
B21	GND	Power Ground	PWR GND	---	---

Pin	Signal	Description	Type	Termination	Comment
B22	USB_SSTX0-	USB Super Speed Transmit – (0)	DP-O	AC coupled on module (100nF)	---
B23	USB_SSTX0+	USB Super Speed Transmit + (0)	DP-O	AC coupled on module (100nF)	---
B24	PWR_OK	Power OK	I-3.3	PU 10K 3.3V (S5)	---
B25	USB_SSTX1-	USB Super Speed Transmit – (1)	DP-O	AC coupled on module (100nF)	---
B26	USB_SSTX1+	USB Super Speed Transmit + (1)	DP-O	AC coupled on module (100nF)	---
B27	WDT	Watch Dog Time-Out event	O-3.3	PD 10K	---
B28	HDA_SDIN2 / SNDW0_CLK	Audio Codec Serial Data in 2 Soundwire Clock 0	I-3.3 / O-1.8	nc	HAD_SDIN2 not supported / SoundWire via HW BOM option only
B29	HDA_SDIN1 / SNDW0_DAT	Audio Codec Serial Data in 1 Soundwire Data 0	I-3.3 / O-1.8V	---	--- / SoundWire via HW BOM option only
B30	HDA_SDIN0	Audio Codec Serial Data in 0	I-3.3	---	---
B31	GND	Power Ground	PWR GND	---	---
B32	SPKR	Speaker	O-3.3	PD 100K	SPKR / SATA_LED# share the same PCH IO selectable via setup option (default SATA_LED#)
B33	I2C_CLK	I2C Clock	O-3.3	PU 2K2 (S5)	---
B34	I2C_DAT	I2C Data	I/O-3.3	PU 2K2 (S5)	---
B35	THRM#	Over Temperature Input	I-3.3	PU 10K (S0)	---
B36	USB7-	USB 2.0 Data Pair Port 7 –	DP-I/O	PD 14.25K to 24.8K in PCH	---
B37	USB7+	USB 2.0 Data Pair Port 7 +	DP-I/O	PD 14.25K to 24.8K in PCH	---
B38	USB_4_5_OC#	USB Overcurrent Indicator Port 4/5	I-3.3	PU 10K (S5)	---
B39	USB5-	USB 2.0 Data Pair Port 5 –	DP-I/O	PD 14.25K to 24.8K in PCH	---
B40	USB5+	USB 2.0 Data Pair Port 5 +	DP-I/O	PD 14.25K to 24.8K in PCH	---
B41	GND	Power Ground	PWR GND	---	---
B42	USB3-	USB 2.0 Data Pair Port 3 –	DP-I/O	PD 14.25K to 24.8K in PCH	---
B43	USB3+	USB 2.0 Data Pair Port 3 +	DP-I/O	PD 14.25K to 24.8K in PCH	---
B44	USB_0_1_OC#	USB Overcurrent Indicator Port 0/1	I-3.3	PU 10K (S5)	---
B45	USB1-	USB 2.0 Data Pair Port 1 –	DP-I/O	PD 14.25K to 24.8K in PCH	---
B46	USB1+	USB 2.0 Data Pair Port 1 +	DP-I/O	PD 14.25K to 24.8K in PCH	---
B47	ESPI_EN#	Enable/Disable ESPI-Mode/LPC- Mode	I-1.8	PU 20K (S5)	---
B48	USB0_HOST_PRSN	USB Host Present on USB0	I-3.3	PD 47K	---
B49	SYS_RESET#	Reset Button Input	I-3.3	PU 10K (S5)	---
B50	CB_RESET#	Carrier Board Reset	O-3.3	PD 10K	---
B51	GND	Power Ground	PWR GND	---	---
B52	RSVD	Reserved for future use	nc	---	---
B53	RSVD	Reserved for future use	nc	---	---
B54	GPO1	General Purpose Output 1	O-3.3	PD 100K	---
B55	GP_SPI_MISO	General Purpose SPI Master In Slave Out	I-3.3	---	on module 33ohm series termination
B56	GP_SPI_MOSI	General Purpose SPI Master Out Slave In	O-3.3	---	on module 33ohm series termination

Pin	Signal	Description	Type	Termination	Comment
B57	GPO2	General Purpose Output 2	O-3.3	PD 100K	---
B58	PCIE_RX3+	PCI Express Lane 3 Receive +	DP-I	---	---
B59	PCIE_RX3-	PCI Express Lane 3 Receive -	DP-I	---	---
B60	GND	Power Ground	PWR GND	---	---
B61	PCIE_RX2+	PCI Express Lane 2 Receive +	DP-I	---	---
B62	PCIE_RX2-	PCI Express Lane 2 Receive -	DP-I	---	---
B63	GPO3	General Purpose Output 3	O-3.3	PD 100K	---
B64	PCIE_RX1+	PCI Express Lane 1 Receive +	DP-I	---	---
B65	PCIE_RX1-	PCI Express Lane 1 Receive -	DP-I	---	---
B66	WAKE0#	PCI Express Wake Event	I-3.3	PU 10K (S5)	---
B67	WAKE1#	General Purpose Wake Event	I-3.3	PU 10K (S5)	---
B68	PCIE_RX0+	PCI Express Lane 0 Receive +	DP-I	---	---
B69	PCIE_RX0-	PCI Express Lane 0 Receive -	DP-I	---	---
B70	GND	Power Ground	PWR GND	---	---
B71	DDIO_PAIR0+	DDIO Pair 0 +	DP-O	---	---
B72	DDIO_PAIR0-	DDIO Pair 0 -	DP-O	---	---
B73	DDIO_PAIR1+	DDIO Pair 1 +	DP-O	---	---
B74	DDIO_PAIR1-	DDIO Pair 1 -	DP-O	---	---
B75	DDIO_PAIR2+	DDIO Pair 2 +	DP-O	---	---
B76	DDIO_PAIR2-	DDIO Pair 2 -	DP-O	---	---
B77	DDIO_PAIR4+	DDIO Pair 4 +	DP-O	nc	not supported
B78	DDIO_PAIR4-	DDIO Pair 4 -	DP-O	nc	not supported
B79	LVDS_BKLT_EN	LVDS / EDP Panel Backlight On	O-3.3	PD 100K	LVDS/eDP selectable via HW BOM option
B80	GND	Power Ground	PWR GND	---	---
B81	DDIO_PAIR3+	DDIO Pair 3 +	DP-O	---	---
B82	DDIO_PAIR3-	DDIO Pair 3 -	DP-O	---	---
B83	LVDS_BKLT_CTRL	LVDS / EDP Backlight Brightness Control	O-3.3	---	LVDS/EDP_BKLT_CTRL always handled by SoC
B84	VCC_5V_SBY	5V Standby	PWR 5V (S5)	---	optional (not necessary in single supply mode)
B85	VCC_5V_SBY	5V Standby	PWR 5V (S5)	---	---
B86	VCC_5V_SBY	5V Standby	PWR 5V (S5)	---	---
B87	VCC_5V_SBY	5V Standby	PWR 5V (S5)	---	---
B88	BIOS_DIS1#	BIOS Selection Strap 1	I-3.3	PU 10K (S5)	---
B89	DDIO_HPDP	DDIO Hot Plug Detect	I-3.3	PD 100K	---
B90	GND	Power Ground	PWR GND	---	---
B91	DDIO_PAIR5+	DDIO Pair 5 +	DP-O	nc	not supported
B92	DDIO_PAIR5-	DDIO Pair 5 -	DP-O	nc	not supported
B93	DDIO_PAIR6+	DDIO Pair 6 +	DP-O	nc	not supported
B94	DDIO_PAIR6-	DDIO Pair 6 -	DP-O	nc	not supported
B95	DDIO_DDC_AUX_SEL	DDIO DDC/AUX select	I-3.3	PD 1M	---
B96	USB7_HOST_PRSNTP	USB Host Present on USB7	I-3.3	PD 47K	---
B97	SPI_CS#	SPI Chip Select	O-3.3	PU 10K (S5)	---
B98	DDIO_CTRLCLK_AUX+	DDIO CTRLCLK/AUX+	I/O-3.3	PD 100K	PU 2K2 if DDC is selected
B99	DDIO_CTRLDATA_AUX-	DDIO CTRLDATA/AUX-	I/O-3.3	PU 100K (S0)	PU 2K2 if DDC is selected
B100	GND	Power Ground	PWR GND	---	---
B101	FAN_PWMOUT	Fan PWM Output	O-3.3	---	20V protection circuit implemented on module, PD on carrier board needed for proper operation

Pin	Signal	Description	Type	Termination	Comment
B102	FAN_TACHIN	Fan Tach Input	I-3.3	---	20V protection circuit implemented on module
B103	SLEEP#	Sleep Button Input	I-3.3	PU 47K (S5)	20V protection circuit implemented on module
B104	VCC_12V	Main Input Voltage (4.75-20V)	PWR	---	---
B105	VCC_12V	Main Input Voltage (4.75-20V)	PWR	---	---
B106	VCC_12V	Main Input Voltage (4.75-20V)	PWR	---	---
B107	VCC_12V	Main Input Voltage (4.75-20V)	PWR	---	---
B108	VCC_12V	Main Input Voltage (4.75-20V)	PWR	---	---
B109	VCC_12V	Main Input Voltage (4.75-20V)	PWR	---	---
B110	GND	Power Ground	PWR GND	---	---

4.3.3. Changes between COM.0 Rev 3.0 and Rev 3.1

Table 38: Comparison Pinout Type 10 COM.0 Rev 3.0 vs. Rev 3.1

Pin	Type 10 Rev 3.0	Type 10 Rev 3.1	Comment
A48	RSVD	RSMRST_OUT#	Carrier should not have 5V VBUS power enabled before RSMRST_OUT# transitions to HIGH state.
A55	RSVD	GP_SPI_CS#	General Purpose SPI Interface
A56	RSVD	GP_SPI_CK	
B28	HDA_SDIN2	HDA_SDIN2/SNDW0_CLK	SoundWire overlay on HAD_SDIN[1:2] pins. (V_HDA=3.3V <-> V_SNDW=1.8V)
B29	HDA_SDIN1	HDA_SDIN1/SNDW0_DAT	
B55	RSVD	GP_SPI_MOSI	General Purpose SPI Interface

5/UEFI BIOS

5.1. Starting the UEFI BIOS

The COMe-mAS10 (E2) uses a JUMPTec-customized, pre-installed and configured version of AMI Aptio® V BIOS based on the Unified Extensible Firmware Interface (UEFI) specification and the Intel® Platform Innovation Framework for EFI.

The UEFI BIOS provides a variety of new and enhanced functions specifically tailored to the hardware features of the COMe-mAS10 (E2).



This chapter provides an overview of the BIOS and its setup. A more detailed listing and description of all BIOS setup nodes can be found in the BIOS file package available on our [Customer Section](#). Please register there to get access to BIOS downloads and Product Change Notifications.

The UEFI BIOS comes with a Setup program that provides quick and easy access to the individual function settings for control or modification of the default configuration. The Setup program allows access to various menus resp. sub-menus that provide the specific functions.

To start the UEFI BIOS Setup program, follow the steps below:

1. Power on the board
2. Wait until the first characters appear on the screen (POST messages or splash screen)
3. Press the key
4. If the UEFI BIOS is password-protected, a request for password will appear. Enter either the User Password or the Supervisor Password (see Security Setup Menu), press <RETURN>, and proceed with step 5.
5. The Setup menu appears

5.2. Navigating the UEFI BIOS

The COMe-mAS10 (E2) UEFI BIOS Setup program uses a hot key navigation system. The hot key legend bar is located at the bottom of the Setup screens. The following table provides a list of navigation hot keys available in the legend bar.

Table 39: Navigation Hot Keys Available in the Legend Bar

Sub-screen	Description
<F1>	<F1> key invokes the General Help window
<->	<Minus> key selects the next lower value within a field
<+>	<Plus> key selects the next higher value within a field
<F2>	<F2> key loads previous values
<F3>	<F3> key loads optimized defaults
<F4>	<F4> key Saves and Exits
<←> or <→>	<Left/Right> arrows selects major Setup menus on menu bar, for example, Main or Advanced
<↑> or <↓>	<Up/Down> arrows select fields in the current menu, for example, Setup function or sub-screen
<ESC>	<ESC> key exits a major Setup menu and enters the Exit Setup menu Pressing the <ESC> key in a sub-menu displays the next higher menu level
<RETURN>	<RETURN> key executes a command or selects a submenu

5.3. Setup Menus

The Setup utility features a selection bar at the top of the screen that lists the menus.



Figure 7: Setup Menu Selection Bar

The Setup menus available for the COMe-bID7 are:

- Main
- Advanced
- Security
- Boot
- Save & Exit

The currently active menu and the currently active UEFI BIOS Setup item are highlighted in white. Use the left and right arrow keys to select the Setup menus.

Each Setup menu provides two main frames. The left frame displays all available functions. Configurable functions are displayed in blue. Functions displayed in grey provide information about the status or the operational configuration.

5.4. Getting Help

The right frame displays a Help window providing an explanation of the respective function.

5.5. UEFI Shell

The JUMPTec UEFI BIOS features a built-in and enhanced version of the UEFI Shell. For a detailed description of the available standard shell scripting, refer to the EFI Shell User Guide. For a detailed description of the available standard shell commands, refer to the EFI Shell Command Manual. Both documents can be downloaded from the EFI and Framework Open Source Community homepage:

<http://sourceforge.net/projects/efi-shell/files/documents/>



JUMPTec UEFI BIOS does not provide all shell commands described in the EFI Shell Command Manual.

5.5.1. Entering the UEFI Shell

To enter the UEFI Shell, follow the steps below:

1. Power on the board
2. Press the <F7> key (instead of) to display a choice of boot devices
3. Select 'UEFI: Built-in EFI shell'

```
UEFI Interactive Shell v2.2
EDK II / JUMPTec add-on v0.3
UEFI v2.80 (American Megatrends, 0x0005001A)
map: No mapping found.
```

4. Press the <ESC> key within 5 seconds to skip startup.nsh or any other key to continue
The output produced by the device-mapping table can vary depending on the board's configuration
If the <ESC> key is pressed before the 5 second timeout elapses, the shell prompt is shown:

```
Shell>
```

5.5.2. Exiting the UEFI Shell

To exit the UEFI Shell, follow one of the steps below:

- Use the *exit* UEFI Shell command to select the boot device, in the Boot menu, that the OS boots from
- Reset the board using the *reset* UEFI Shell command
- Press the reset button of the board or power down/up the board

5.6. UEFI Shell Scripting

5.6.1. Startup Scripting

If the <ESC key is not pressed and the timeout has run out then the UEFI Shell automatically tries to execute some startup scripts. It searches for scripts and executes them in the following order:

1. Initially searches for JUMPTec flash-stored startup script.
2. If there is no JUMPTec flash-stored startup script present, then the UEFI-specified **startup.nsh** script is used. This script must be located on the root of any of the attached FAT formatted disk drive.
3. If none of the startup scripts are present or the startup script terminates then the default boot order is continued.

5.6.2. Create a Startup Script

Startup scripts can be created using the UEFI Shell built-in editor **edit** or under any OS with a plain text editor of your choice.

5.6.3. Example of Startup Scripts

Execute Shell Script on other Harddrive

This example (**startup.nsh**) executes the shell script named **bootme.nsh** located in the root of the first detected disk drive (**fs0**).

```
fs0:  
bootme.nsh
```

5.7. Firmware Update

Firmware updates are typically delivered as a ZIP archive. Please find the latest available BIOS-ZIP archive on JUMPTec's [Customer Section](#). Further information about the firmware update procedure can be found in the included "flash_instruction.txt"-file.



Register to JUMPTec's [Customer Section](#) to get access to BIOS downloads, additional documentation and Product Change Notification service.

6/Technical Support

For technical support contact our Support Department:

- › E-mail: techsupport@jumptec.com

Make sure you have the following information available when you call:

- › Product ID Number (P/N),
- › Serial Number (SN) Module's revision
- › Operating System and Kernel/Build version
- › Software modifications
- › Additional connected hardware/full description of hardware set up



The serial number can be found on the Type Label, located on the product's rear panel.

Be ready to explain the nature of your problem to the service technician.

6.1. Warranty

Due to their limited service life, parts that by their nature are subject to a particularly high degree of wear (wearing parts) are excluded from the warranty beyond that provided by law. This applies to the lithium battery, for example.



If there is a protection label on your product, then the warranty is lost if the product is opened.

6.2. Returning Defective Merchandise

All equipment returned to JUMPTec must have a Return of Material Authorization (RMA) number assigned exclusively by JUMPTec. JUMPTec cannot be held responsible for any loss or damage caused to the equipment received without an RMA number. The buyer accepts responsibility for all freight charges for the return of goods to JUMPTec's designated facility. JUMPTec will pay the return freight charges back to the buyer's location in the event that the equipment is repaired or replaced within the stipulated warranty period. Follow these steps before returning any product to JUMPTec.

1. Visit the RMA Information website: <https://www.congatec.com/en/support/rma-information>
2. **Download the RMA Request sheet for JUMPTec GmbH and fill out the form. Take care to include a short detailed description of the observed problem or failure and to include the product identification Information (Name of product, Product number and Serial number). If a delivery includes more than one product, fill out the above information in the RMA Request form for each product.**
3. Send the completed RMA-Request form to the email address given at JUMPTec GmbH. JUMPTec will provide an RMA-Number.
4. The goods for repair must be packed properly for shipping, considering shock and ESD protection.



Goods returned to JUMPTec GmbH in non-proper packaging will be considered as customer caused faults and cannot be accepted as warranty repairs

5. Include the RMA-Number with the shipping paperwork and send the product to the delivery address provided in the RMA form or received from JUMPTec RMA Support.

7/Storage and Transportation

7.1. Storage

If the product is not in use for an extended period time, disconnect the power plug from the power supply. If it is necessary to store the product then re-pack the product as originally delivered to avoid damage. The storage facility must meet the products environmental storage requirements as stated within this user guide. JUMPtEC recommends keeping the original packaging material for future storage or warranty shipments.

7.2. Transportation

To ship the product use the original packaging, designed to withstand impact and adequately protect the product. When packing or unpacking products always take shock and ESD protection into consideration and use an EOS/ESD safe working area.



About JUMPtec

JUMPtec specializes its technical expertise in designing both - standard and highly customized compute products. Our newly optimized structure enables us to take customers from prototyping and design through to mass production faster than ever before.

JUMPtec serves a diverse range of markets, providing innovative solutions tailored to the unique needs of each industry. Find out more about our offering!

For more information, please visit: www.jumptec.com

JUMPtec GmbH

Brunnwiesenstrasse 16
94469 Deggendorf
Germany
Tel.: + 49 991 37024-0

info@jumptec.com
www.congatec.com

