

COMe-mEL10

User Guide Rev. 1.5

This page has been intentionally left blank

▶ COME-MEL10 - USER GUIDE

Disclaimer

JUMPttec would like to point out that the information contained in this user guide may be subject to alteration, particularly as a result of the constant upgrading of JUMPttec products. This document does not entail any guarantee on the part of JUMPttec with respect to technical processes described in the user guide or any product characteristics set out in the user guide. JUMPttec assumes no responsibility or liability for the use of the described product(s), conveys no license or title under any patent, copyright or mask work rights to these products and makes no representations or warranties that these products are free from patent, copyright or mask work right infringement unless otherwise specified. Applications that are described in this user guide are for illustration purposes only. JUMPttec makes no representation or warranty that such application will be suitable for the specified use without further testing or modification. JUMPttec expressly informs the user that this user guide only contains a general description of processes and instructions which may not be applicable in every individual case. In cases of doubt, please contact JUMPttec.

This user guide is protected by copyright. All rights are reserved by JUMPttec. No part of this document may be reproduced, transmitted, transcribed, stored in a retrieval system, or translated into any language or computer language, in any form or by any means (electronic, mechanical, photocopying, recording, or otherwise), without the express written permission of JUMPttec. JUMPttec points out that the information contained in this user guide is constantly being updated in line with the technical alterations and improvements made by JUMPttec to the products and thus this user guide only reflects the technical status of the products by JUMPttec at the time of publishing.

Brand and product names are trademarks or registered trademarks of their respective owners.

©2025 by JUMPttec GmbH

JUMPttec GmbH
Brunnwiesenstrasse 16
94469 Deggendorf
Germany
www.jumpotec.com

Intended Use

This device and associated software are not designed, manufactured or intended for use or resale for the operation of nuclear facilities, the navigation, control or communication systems for aircraft or other transportation, air traffic control, life support or life sustaining applications, weapons systems, or any other application in a hazardous environment, or requiring fail-safe performance, or in which the failure of products could lead directly to death, personal injury, or severe physical or environmental damage (collectively, "high risk applications").

You understand and agree that your use of JUMPtec devices as a component in High Risk Applications is entirely at your risk. To minimize the risks associated with your products and applications, you should provide adequate design and operating safeguards. You are solely responsible for compliance with all legal, regulatory, safety, and security related requirements concerning your products. You are responsible to ensure that your systems (and any JUMPtec hardware or software components incorporated in your systems) meet all applicable requirements. Unless otherwise stated in the product documentation, the JUMPtec device is not provided with error-tolerance capabilities and cannot therefore be deemed as being engineered, manufactured or setup to be compliant for implementation or for resale as device in High Risk Applications. All application and safety related information in this document (including application descriptions, suggested safety measures, suggested JUMPtec products, and other materials) is provided for reference only.

NOTICE

You find the most recent version of the "General Safety Instructions" online in the download area of this product on our [JUMPtec website](#).

NOTICE

This product is not intended for use or suited for storage or operation in corrosive environments, in particular under exposure to sulfur and chlorine and their compounds. For information on how to harden electronics and mechanics against these stress conditions, contact JUMPtec Support.

Revision History

Revision	Brief Description of Changes	Date of Issue	Author/Editor
1.0	Initial version	2021-July-23	CW
1.1	Added Tjunction temperature range to Table 5: Processor Specification	2021-Sept-09	CW
1.2	GPIO update Chapter 3.5	2022-Jul-28	CW
1.3	Updated eMMC information, Kontron logo	2023-Jul-17	IH
1.4	Added further DTR information, added GBE-LINK description	2024-Nov-26	IH
1.5	Remove chapter for BIOS.. now included in BIOS package	2025-Nov-06	IH

Terms and Conditions

JUMPTec warrants products in accordance with defined regional warranty periods. For more information about warranty compliance and conformity, and the warranty period in your region, visit <https://www.jumpotec.com/en/terms-and-conditions>.

JUMPTec sells products worldwide and declares regional General Terms & Conditions of Sale, and Purchase Order Terms & Conditions. Visit <https://www.jumpotec.com/en/terms-and-conditions>.

For contact information, refer to the corporate offices contact information on the last page of this user guide or visit our website [CONTACT US](#).

Customer Support

Find JUMPTec contacts by visiting <https://www.jumpotec.com/en/service-support>.

Customer Service

As a trusted technology innovator and global solutions provider, JUMPTec extends its embedded market strengths into a services portfolio allowing companies to break the barriers of traditional product lifecycles. Proven product expertise coupled with collaborative and highly-experienced support enables JUMPTec to provide exceptional peace of mind to build and maintain successful products.

For more details on JUMPTec's service offerings such as: enhanced repair services, extended warranty, JUMPTec training academy, and more visit <https://www.jumpotec.com/en/service-support>.

Customer Comments

If you have any difficulties using this user guide, discover an error, or just want to provide some feedback, contact [JUMPTec Support](#). Detail any errors you find. We will correct the errors or problems as soon as possible and post the revised user guide on our website.

Symbols

The following symbols may be used in this user guide



DANGER indicates a hazardous situation which, if not avoided, will result in death or serious injury.



WARNING indicates a hazardous situation which, if not avoided, could result in death or serious injury.



NOTICE indicates a property damage message.



CAUTION indicates a hazardous situation which, if not avoided, may result in minor or moderate injury
ATTENTION indique une situation dangereuse qui, si elle n'est pas évitée, peut entraîner des blessures mineures ou modérées.



Electric Shock!

This symbol and title warn of hazards due to electrical shocks (> 60 V) when touching products or parts of products. Failure to observe the precautions indicated and/or prescribed by the law may endanger your life/health and/or result in damage to your material.



ESD Sensitive Device!

This symbol and title inform that the electronic boards and their components are sensitive to static electricity. Care must therefore be taken during all handling operations and inspections of this product in order to ensure product integrity at all times.



Caution: HOT Surface!

Do NOT touch! Allow to cool before servicing.

Attention : Surface CHAUDE !

Ne pas toucher ! Laissez refroidir avant de procéder à l'entretien.



Caution: Laser!

This symbol inform of the risk of exposure to laser beam and light emitting devices (LEDs) from an electrical device. Eye protection per manufacturer notice shall review before servicing.



This symbol indicates general information about the product and the user guide.
This symbol also indicates detail information about the specific product configuration.



This symbol precedes helpful hints and tips for daily use.

For Your Safety

Your new JUMPtec product was developed and tested carefully to provide all features necessary to ensure its compliance with electrical safety requirements. It was also designed for a long fault-free life. However, the life expectancy of your product can be drastically reduced by improper treatment during unpacking and installation. Therefore, in the interest of your own safety and of the correct operation of your new JUMPtec product, you are requested to conform with the following guidelines.

High Voltage Safety Instructions

As a precaution and in case of danger, the power connector must be easily accessible. The power connector is the product's main disconnect device.

CAUTION

Warning

All operations on this product must be carried out by sufficiently skilled personnel only.

CAUTION

Electric Shock!

Before installing a non hot-swappable JUMPtec product into a system always ensure that your mains power is switched off. This also applies to the installation of piggybacks. Serious electrical shock hazards can exist during all installation, repair, and maintenance operations on this product. Therefore, always unplug the power cable and any other cables which provide external voltages before performing any work on this product.

Earth ground connection to vehicle's chassis or a central grounding point shall remain connected. The earth ground cable shall be the last cable to be disconnected or the first cable to be connected when performing installation or removal procedures on this product.

Special Handling and Unpacking Instruction

NOTICE

ESD Sensitive Device!

Electronic boards and their components are sensitive to static electricity. Therefore, care must be taken during all handling operations and inspections of this product, in order to ensure product integrity at all times.

CAUTION

Handling and operation of the product is permitted only for trained personnel within a work place that is access controlled. Follow the "General Safety Instructions" supplied with the product.

Do not handle this product out of its protective enclosure while it is not used for operational purposes unless it is otherwise protected.

Whenever possible, unpack or pack this product only at EOS/ESD safe work stations. Where a safe work station is not guaranteed, it is important for the user to be electrically discharged before touching the product with his/her hands or tools. This is most easily done by touching a metal part of your system housing.

It is particularly important to observe standard anti-static precautions when changing piggybacks, ROM devices, jumper settings etc. If the product contains batteries for RTC or memory backup, ensure that the product is not placed on conductive surfaces, including anti-static plastics or sponges. They can cause short circuits and damage the batteries or conductive circuits on the product.

Lithium Battery Precautions

If your product is equipped with a lithium battery, take the following precautions when replacing the lithium battery.

⚠ CAUTION

Risk of Explosion if the lithium Battery is replaced by an incorrect Type. Dispose of used lithium batteries According to the instructions.

Risque d'explosion si la pile au lithium est remplacée par une pile de type incorrect. Éliminez les piles au lithium usagées conformément aux instructions.

General Instructions on Usage

In order to maintain JUMPtec's product warranty, this product must not be altered or modified in any way. Changes or modifications to the product, that are not explicitly approved by JUMPtec and described in this user guide or received from [JUMPtec Support](#) as a special handling instruction, will void your warranty.

This product should only be installed in or connected to systems that fulfill all necessary technical and specific environmental requirements. This also applies to the operational temperature range of the specific board version that must not be exceeded. If batteries are present, their temperature restrictions must be taken into account.

In performing all necessary installation and application operations, only follow the instructions supplied by the present user guide.

Keep all the original packaging material for future storage or warranty shipments. If it is necessary to store or ship the product then re-pack it in the same manner as it was delivered.

Special care is necessary when handling or unpacking the product. See Special Handling and Unpacking Instruction.

Quality and Environmental Management

JUMPtec aims to deliver reliable high-end products designed and built for quality, and aims to complying with environmental laws, regulations, and other environmentally oriented requirements. For more information regarding JUMPtec's quality and environmental responsibilities, visit <https://www.jumptec.com/en/about-jumptec/quality>.

Disposal and Recycling

JUMPttec's products are manufactured to satisfy environmental protection requirements where possible. Many of the components used are capable of being recycled. Final disposal of this product after its service life must be accomplished in accordance with applicable country, state, or local laws or regulations.

WEEE Compliance

The Waste Electrical and Electronic Equipment (WEEE) Directive aims to:

- Reduce waste arising from electrical and electronic equipment (EEE)
- Make producers of EEE responsible for the environmental impact of their products, especially when the product become waste
- Encourage separate collection and subsequent treatment, reuse, recovery, recycling and sound environmental disposal of EEE
- Improve the environmental performance of all those involved during the lifecycle of EEE



Environmental protection is a high priority with JUMPttec.

JUMPttec follows the WEEE directive

You are encouraged to return our products for proper disposal.

Table of Contents

Intended Use.....	4
Terms and Conditions	5
Customer Support	5
Customer Service.....	5
Customer Comments.....	5
Symbols.....	6
For Your Safety	8
High Voltage Safety Instructions	8
Special Handling and Unpacking Instruction	8
Lithium Battery Precautions.....	9
General Instructions on Usage.....	9
Quality and Environmental Management.....	9
Disposal and Recycling.....	9
WEEE Compliance.....	10
Table of Contents.....	11
List of Tables.....	13
List of Figures.....	14
1/ General Safety Instructions	15
1.1. Electrostatic Discharge (ESD).....	16
1.2. Grounding Methods.....	16
1.3. Instructions for Lithium Battery.....	16
2/ Introduction	18
2.1. Product Description.....	18
2.2. Product Naming Clarification	19
2.3. COM Express® Documentation	20
2.4. COM Express® Functionality.....	20
2.5. COM Express® Benefits	20
3/ Product Specification	21
3.1. Module Variants	21
3.1.1. Commercial Grade Modules (0°C to +60°C).....	21
3.1.2. Industrial Temperature Grade Modules (E2, -40°C to +85°C)	21
3.2. Accessories.....	21
3.3. Functional Specification.....	23
3.3.1. Block Diagram.....	23
3.3.2. Processors.....	23
3.3.3. Platform Controller Hub (PCH)	25
3.3.4. System Memory	25
3.3.5. Graphics (LVDS or eDP, and DP++)	26
3.3.6. HD Audio.....	26
3.3.7. PCI Express Lanes [0-3]	26
3.3.8. USB.....	27
3.3.9. SATA	29
3.3.10. Ethernet LAN.....	29
3.3.11. COMe High-speed Serial Interfaces Overview	30
3.3.12. Storage.....	30

3.3.13. BIOS/Software Features..... 30

3.3.14. Features 30

3.4. Electrical Specification..... 32

3.4.1. Power Supply Specification..... 32

3.4.2. Power Management 33

3.4.3. Power Supply Modes..... 34

3.5. Thermal Management 36

3.5.1. Heatspreader Plate Assembly and Metal Heat Slug..... 36

3.5.2. Active/Passive Cooling Solutions..... 36

3.5.3. Operating with the Heatspreader Plate (HSP) Assembly..... 36

3.5.4. Operating without the Heatspreader Plate (HSP) Assembly 36

3.5.5. Temperature Sensors..... 37

3.5.6. On-Module Fan Connector..... 38

3.6. Environmental Specification..... 38

3.7. Standards and Certifications 39

3.7.1. MTBF 39

3.8. Mechanical Specification 41

3.8.1. Module Dimensions 41

3.8.2. Module Height..... 42

3.8.3. Metal Heat Slug Dimensions..... 42

4/ Features and Interfaces 44

4.1. ACPI Power States 44

4.2. eMMC Flash Memory (option) 44

4.3. eSPI Mode (option) 44

4.4. Fast I2C 45

4.5. GPIO..... 45

4.6. Hardware Monitor (HWM) 45

4.7. LPC..... 46

4.8. Intel® PSE..... 46

4.9. Intel® TCC..... 46

4.10. Real Time Clock..... 46

4.11. SDIO (option)..... 47

4.12. Serial Peripheral Interface (SPI) 47

4.12.1. SPI Boot..... 47

4.12.2. Booting the SPI Flash Chip 48

4.12.3. External SPI Flash Boot on Modules with Intel® Management Engine..... 48

4.13. TPM 2.0 48

4.14. UART 49

4.15. Watchdog Timer (WTD) Dual Stage 49

4.15.1. Watchdog Timer Signal..... 49

5/ System Resources 50

5.1. I2C Bus..... 50

5.2. System Management (SM) Bus 50

6/ COMe Interface Connector..... 51

6.1. Connecting COMe Interface Connector to Carrier Board 51

6.2. X1A Signals..... 52

6.3. COMe Interface Connector (X1A) Pin Assignment 53

6.3.1. Connector X1A Row A1 – A110.....	53
6.3.2. Connector X1A Row B1 – B110.....	56
7/ UEFI BIOS.....	60
7.1. Starting the UEFI BIOS.....	60
7.2. Navigating the UEFI BIOS.....	60
7.3. Setup Menus.....	61
7.4. Getting Help.....	61
7.5. UEFI Shell.....	61
7.5.1. Entering the UEFI Shell.....	61
7.5.2. Exiting the UEFI Shell.....	62
7.6. UEFI Shell Scripting.....	62
7.6.1. Startup Scripting.....	62
7.6.2. Create a Startup Script.....	62
7.6.3. Example of Startup Scripts.....	62
7.7. Firmware Update.....	63
8/ Technical Support.....	64
8.1. Warranty.....	64
8.2. Returning Defective Merchandise.....	64
9/ Storage and Transportation.....	65
9.1. Storage.....	65
9.2. Transportation.....	65

List of Tables

Table 1: Type 10 and COMe-mEL10 Functionality.....	20
Table 2: Product Number for Commercial Grade Modules (0°C to +60°C operating).....	21
Table 3: Product Number for Industrial Grade Modules (-40°C to +85°C operating).....	21
Table 4: Accessories.....	21
Table 5: Processor Specification.....	24
Table 6: COMe-mEL10 Electrical Specification.....	32
Table 7: Power Supply Control Settings.....	33
Table 8: ATX Mode Settings.....	34
Table 9: Single Power Supply Mode Settings.....	35
Table 10: Heatspreader Temperature Specification.....	36
Table 11: Fan Connector (3-Pin) Pin Assignment.....	38
Table 12: Temperature Grades and Humidity Specification.....	38
Table 13: Standards and Certifications.....	39
Table 14: MTBF.....	39
Table 15: Supported Power States Function.....	44
Table 16: SPI Boot Pin Configuration.....	47
Table 17: Supported SPI Boot Flash Types:.....	47
Table 18: Dual Staged Watchdog Timer- Time-Out Events.....	49
Table 19: I2C Bus Port Address.....	50
Table 20: SMBus Address.....	50
Table 21: General Signal Description.....	52
Table 22: Connector X1A Row A1 to A110 Pin Assignment.....	53
Table 23: Connector X1A Row B1 to B110 Pin Assignment.....	56
Table 24: Navigation Hot Keys Available in the Legend Bar.....	60

List of Figures

Figure 1: COMe-mEL10 Front Side	18
Figure 2: COM-mEL10 Bottom Side.....	19
Figure 3: Block Diagram COMe-mEL10.....	23
Figure 4: Module Temperature Sensors.....	37
Figure 5: Fan Connector 3-Pin.....	38
Figure 6: MTBF De-rating Values	40
Figure 7: Module Dimensions	41
Figure 8: Module and Carrier Height.....	42
Figure 9: Metal Heat Slug Dimensions	42
Figure 10: COMe Interface Connector	51
Figure 7: Setup Menu Selection Bar.....	61

1/ General Safety Instructions

Please read this passage carefully and take careful note of the instructions, which have been compiled for your safety and to ensure to apply in accordance with intended regulations. If the following general safety instructions are not observed, it could lead to injuries to the operator and/or damage of the product; in cases of non-observance of the instructions JUMPtec is exempt from accident liability, this also applies during the warranty period.

The product has been built and tested according to the basic safety requirements for low voltage (LVD) applications and has left the manufacturer in safety-related, flawless condition. To maintain this condition and to also ensure safe operation, the operator must not only observe the correct operating conditions for the product but also the following general safety instructions:

- ▶ The product must be used as specified in the product documentation, in which the instructions for safety for the product and for the operator are described. These contain guidelines for setting up, installation and assembly, maintenance, transport or storage.
- ▶ The on-site electrical installation must meet the requirements of the country's specific local regulations.
- ▶ If a power cable comes with the product, only this cable should be used. Do not use an extension cable to connect the product.
- ▶ To guarantee that sufficient air circulation is available to cool the product, please ensure that the ventilation openings are not covered or blocked. If a filter mat is provided, this should be cleaned regularly. Do not place the product close to heat sources or damp places. Make sure the product is well ventilated.
- ▶ Only connect the product to an external power supply providing the voltage type (AC or DC) and the input power (max. current) specified on the JUMPtec Product Label and meeting the requirements of the Limited Power Source (LPS) and Power Source (PS2) of UL/IEC 62368-1 .
- ▶ Only products or parts that meet the requirements for Power Source (PS1) of UL/IEC 62368-1 may be connected to the product's available interfaces (I/O).
- ▶ Before opening the product, make sure that the product is disconnected from the mains.
- ▶ Switching off the product by its power button does not disconnect it from the mains. Complete disconnection is only possible if the power cable is removed from the wall plug or from the product. Ensure that there is free and easy access to enable disconnection.
- ▶ The product may only be opened for the insertion or removal of add-on cards (depending on the configuration of the product). This may only be carried out by qualified operators.
- ▶ If extensions are being carried out, the following must be observed:
 - all effective legal regulations and all technical data are adhered to
 - the power consumption of any add-on card does not exceed the specified limitations
 - the current consumption of the product does not exceed the value stated on the product label
- ▶ Only original accessories that have been approved by JUMPtec can be used.
- ▶ Please note: safe operation is no longer possible when any of the following applies:
 - the product has visible damages or
 - the product is no longer functioning
 In this case the product must be switched off and it must be ensured that the product can no longer be operated.
- ▶ Handling and operation of the product is permitted only for trained personnel within a work place that is access controlled.
- ▶ CAUTION: Risk of explosion if the lithium battery is replaced incorrectly (short-circuited, reverse-poled, wrong lithium battery type). Dispose of used lithium batteries according to the manufacturer's instructions.
- ▶ This product is not suitable for use in locations where children are likely to be present

Additional Safety Instructions for DC Power Supply Circuits

- ▶ To guarantee safe operation, please observe that:
 - ▶ the external DC power supply must meet the criteria for LPS and PS2 (UL/IEC 62368-1)
 - ▶ no cables or parts without insulation in electrical circuits with dangerous voltage or power should be touched directly or indirectly
 - ▶ a reliable functional earth connection is provided
 - ▶ a suitable, easily accessible disconnecting device is used in the application (e.g. overcurrent protective device), if the product itself is not disconnect able
 - ▶ a disconnect device, if provided in or as part of the product, shall disconnect both poles simultaneously
 - ▶ interconnecting power circuits of different products cause no electrical hazards
- ▶ A sufficient dimensioning of the power cable wires must be selected – according to the maximum electrical specifications on the product label – as stipulated by EN62368-1 or VDE0100 or EN60204 or UL61010-1 regulations.

For the General Safety Instruction in German or French, visit JUMPtec's product web page> Downloads> Manuals> General Safety Instructions.

1.1. Electrostatic Discharge (ESD)

A sudden discharge of electrostatic electricity can destroy static-sensitive devices or micro-circuitry. Therefore, proper packaging and grounding techniques are necessary precautions to prevent damage.

Always take the following precautions:



ESD Sensitive Device!

Keep electrostatic sensitive parts in their containers until they arrive at the ESD-safe workplace. Always be properly grounded when touching a sensitive board, component, or assembly.

For more Information, see the Special Handling and Unpacking Instruction within this user guide and the following Chapter Grounding Methods.

1.2. Grounding Methods

The following measures help to avoid electrostatic damages to the device:

- ▶ Cover workstations with approved antistatic material. Always wear a wrist strap connected to the workplace, as well as properly grounded tools and equipment.
- ▶ Use antistatic mats, heel straps, or air ionizers for more protection.
- ▶ Always handle electrostatically sensitive components by their edge or by their casing.
- ▶ Avoid contact with pins, leads, or circuitry.
- ▶ Switch off power and input signals before inserting and removing connectors or connecting test equipment.
- ▶ Keep the work area free of non-conductive materials such as ordinary plastic assembly aids and styrofoam.
- ▶ Use field service tools such as cutters, screwdrivers, and vacuum cleaners that are conductive.
- ▶ Always place drives and boards with the PCB-assembly-side down on the foam.

1.3. Instructions for Lithium Battery

If the product is equipped with a lithium battery, there is a risk of explosion if the lithium battery is replaced incorrectly (short-circuited, reverse-poled, wrong lithium battery type). Dispose of used batteries according to the manufacturer's instructions.

⚠ CAUTION

Risk of Explosion if the lithium battery is replaced by an incorrect Type. Dispose of used batteries according to the instructions.

Risque d'explosion si la pile au lithium est remplacée par une pile de type incorrect. Éliminez les piles au lithium usagées conformément aux instructions



Do not dispose of lithium batteries in general trash collection. Dispose of the lithium battery according to the local regulations dealing with the disposal of these special materials, (e.g. to the collecting points for dispose of batteries).

2/ Introduction

This user guide describes the COMe-mEL10 module and focuses on describing the modules special features. It is strongly recommended that users study this user guide before powering on the module.

2.1. Product Description

The COMe-mEL10 is small form factor COM Express® type 10 Computer-On-Module designed for flexible implementation within multiple embedded industrial environments. The COMe-mEL10 is based on the Intel® Multi Chip Package (MCP) Atom™, Pentium® and Celeron® processors with an integrated PCH to combine increased efficiency and performance with TDP as low as 6 W and no more than 12 W, and includes Intel's® extensive HD Graphics capabilities.

Key COMe-mEL10 features are:

- ▶ Intel® Multi Chip Package series of Atom™, Pentium® and Celeron® processors
- ▶ Small form-factor COM Express® mini Type 10 pinout, compatible with PICMG COM.0 Rev 3.0 spec
- ▶ Up to 16 GByte LPDDR4 memory down (with in-band ECC)
- ▶ High-speed connectivity 4x PCI Express, 1x 1 Gb Ethernet, 2x USB 3.1 + 6x USB 2.0, 2x SATA Gen.3
- ▶ Support for Industrial and commercial temperature grade environments

Figure 1: COMe-mEL10 Front Side

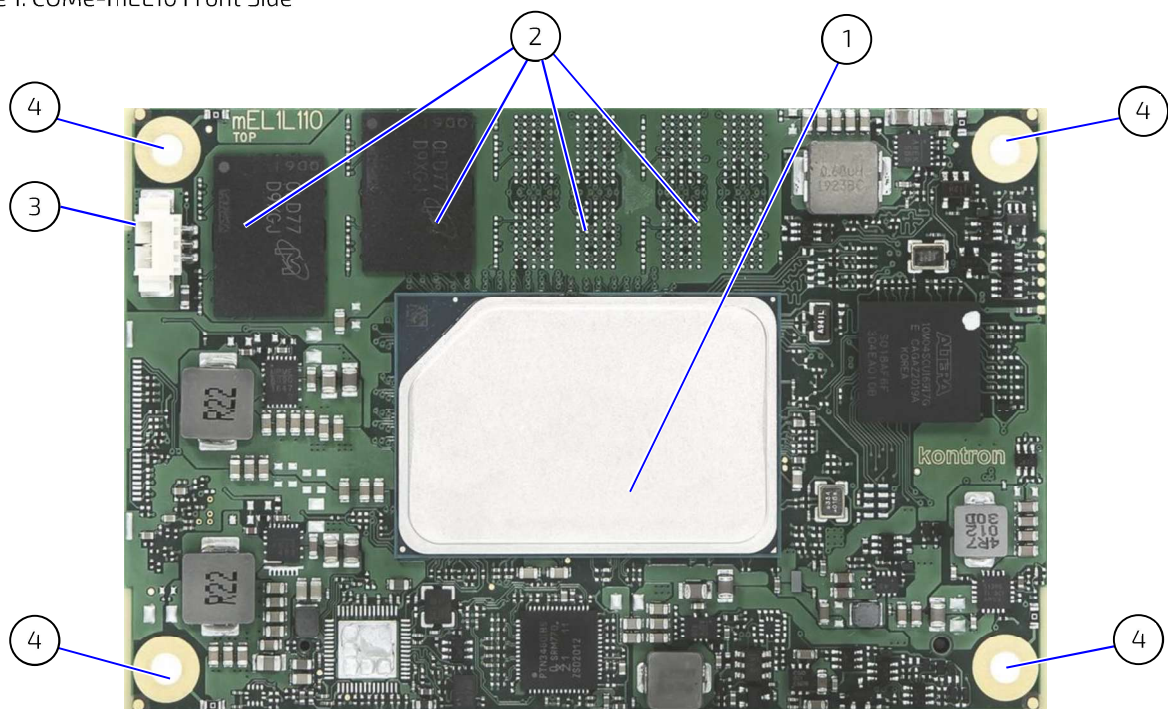

- | | | | |
|---|--|---|----------------------------------|
| 1 | Multi-Chip Package (MCP) | 3 | 3-pin fan connector |
| 2 | Up to 4 memory chips depending on the capacity | 4 | 4x mounting points for standoffs |

Figure 2: COM-mEL10 Bottom Side

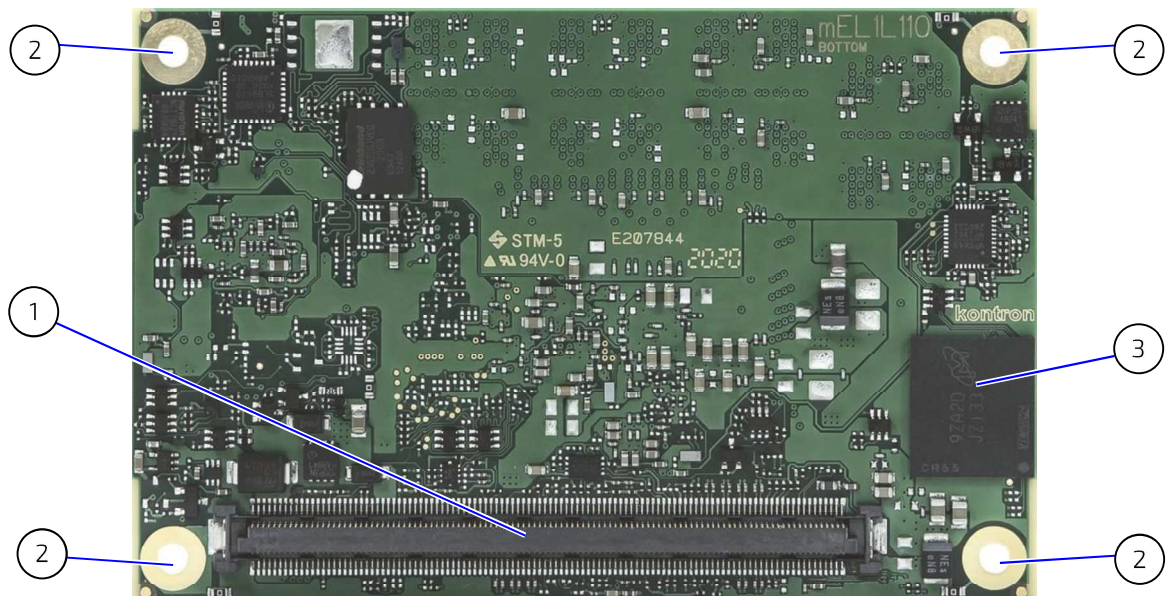

- | | | | |
|---|--------------------------------|---|-----------------------------------|
| 1 | COMe interface connector (X1A) | 2 | 4x Mounting points for stand offs |
| | | 3 | eMMC |

2.2. Product Naming Clarification

COM Express® defines a Computer-On-Module (COM), with all the components necessary for a bootable host computer, packaged as a super component. The product name for the COM Express® Computer-On-Modules consists of:

- ▶ Industry standard short form
 - ▶ COMe-
- ▶ Module form factor
 - ▶ b=basic (125mm x 95mm)
 - ▶ c=compact (95mm x 95mm)
 - ▶ m=mini (84mm x 55mm)
- ▶ Processor family identifier
 - ▶ EL
- ▶ Pinout type
 - ▶ Type 10
 - ▶ Type 7
 - ▶ Type 6
- ▶ Available temperature variants
 - ▶ Commercial
 - ▶ Extended (E1)
 - ▶ Industrial (E2)
 - ▶ Screened industrial (E2S)
- ▶ Processor Identifier
- ▶ Chipset identifier (if assembled)
- ▶ Memory (#G) / eMMC (#G/S for pSLC)

2.3. COM Express® Documentation

The COM Express® specification defines the COM Express® module form factor, pinout and signals. For more information about the COM Express® specification, visit the [PCI Industrial Computer Manufacturers Group \(PICMG®\)](http://www.pcmg.org) website.

2.4. COM Express® Functionality

All COM Express® mini modules contain one 220-pin connector containing two rows called row A & row B. The COM Express® mini Computer-On-Module (COM) features the following maximum amount of interfaces according to the PICMG module pinout type.

Table 1: Type 10 and COMe-mEL10 Functionality

Feature	Type 10	COMe-mEL10
HD Audio	1x	1x
Gbit Ethernet	1x	1x
Serial ATA Gen3	2x	2x
PCI Express x 1	4x	Up to 4x
USB Client	1x	1x (Port 7 is dual role Client/Host)
USB	2x USB 3.0/2.0 6x USB 2.0	2x USB 3.1 Gen 2/USB 2.0 6x USB 2.0
LVDS (eDP)	1x LVDS single 24-bit channel (with eDP overlay)	1x LVDS single 24-bit channel (with eDP overlay)
DP++ (DP/HDMI/DVI)	1x	1x
SPI	1x	1x
LPC /eSPI	1x	1x
External SMB	1x	1x
I2C	1x	1x
GPIO or SDIO	8x	8x GPIO (with SDIO overlay option)
UART (2-wire COM)	2x	2x
TPM 2.0	1x	1x
FAN PWM out	1x	1x

2.5. COM Express® Benefits

COM Express® defines a Computer-On-Module (COM), with all the components necessary for a bootable host computer, packaged as a highly integrated computer. All COM Express® modules are very compact and feature a standardized form factor and a standardized connector layout that carry a specified set of signals. Each COM module is based on the COM Express® specification. This standardization allows designers to create a single-system carrier board that can accept present and future COM Express® modules.

The carrier board designer can optimize exactly how each of these functions implements physically. Designers can place connectors precisely where needed for the application, on a carrier board optimally designed to fit a system's packaging.

A single carrier board design can use a range of COM Express® modules with different sizes and pinouts. This flexibility differentiates products at various price and performance points and provides a built-in upgrade path when designing future-proof systems. The modularity of a COM Express® solution also ensures against obsolescence when computer technology evolves. A properly designed COM Express® carrier board can work with several successive generations of COM Express® modules.

A COM Express® carrier board design has many advantages of a customized computer-board design and, additionally, delivers better obsolescence protection, heavily reduced engineering effort, and faster time to market

3/ Product Specification

The COMe-mEL10 is available in different processor, memory and temperature variants to cover demands in performance, price and power. The following tables list the module variants for the commercial and industrial temperature grades.

3.1. Module Variants

3.1.1. Commercial Grade Modules (0°C to +60°C)

Table 2: Product Number for Commercial Grade Modules (0°C to +60°C operating)

Product Number	Product Name	Description
34012-0416-N1-2	COMe-mEL10 N6211 4G/16G	COM Express® mini pin-out type 10 with Intel® Celeron® N6211, 2 core, 1.2GHz, 4GB LPDDR4-3200 memory down, GPY115 LAN, 16GB eMMC MLC, commercial temperature
34012-0432-J2-4	COMe-mEL10 J6426 4G/32G	COM Express® mini pin-out type 10 with Intel® Pentium® J6426, 4 core, 2.0GHz, 4GB LPDDR4-3733 memory down, GPY115 LAN, 32GB eMMC MLC, commercial temperature

3.1.2. Industrial Temperature Grade Modules (E2, -40°C to +85°C)

Table 3: Product Number for Industrial Grade Modules (-40°C to +85°C operating)

Product Number	Product Name	Description
34013-0416-R1-2	COMe-mEL10 E2 x6212RE 4G/16G	COM Express® mini pin-out type 10 with Intel® Atom® x6212RE , 2 core, 1.2GHz, 4GB LPDDR4-3200 memory down, GPY115 LAN, 16GB eMMC MLC, industrial temperature
34013-0432-R1-4	COMe-mEL10 E2 x6414RE 4G/32G	COM Express® mini pin-out type 10 with Intel® Atom® x6414RE, 4 core, 1.5GHz, 4GB LPDDR4-3200 memory down, GPY115 LAN, 32GB eMMC MLC, industrial temperature
34013-0832-R2-4	COMe-mEL10 E2 x6425RE 8G/32G	COM Express® mini pin-out type 10 with Intel® Atom® x6425RE , 4 core, 1.9GHz, 8GB LPDDR4-4267 memory down, GPY115 LAN, 32GB eMMC MLC, industrial temperature

3.2. Accessories

The accessories are module specific, COMe-type 10 specific, or general COMe accessories. For more information, visit the [COMe-mEL10 web page](#) or contact your local Sales Representative or Inside Sales.

Table 4: Accessories

Part Number	Carrier	Description
34101-0000-00-2	COMe Eval Carrier T10 GEN2	COM Express® Evaluation Carrier Type 10 Gen 2

Part Number	Carrier	Description
34105-0000-00-x	COMe RefCarrier-i T10 TNIP	COM Express® Reference Carrier-i Type 10 Thin-nano ITX Professional

Part Number	Heatspreader	Description
34013-0000-99-0	HSP COMe-mEL10 (E2) THREAD	Heatspreader for COMe-mEL10 commercial and E2, threaded mounting holes
34013-0000-99-1	HSP COMe-mEL10 (E2) THROUGH	Heatspreader for COMe-mEL10 commercial and E2, through holes
34013-0000-99-2	HSP COMe-mEL10 (E2) SLIM THREAD	Heatspreader slimline 6.5mm for COMe-mEL10 commercial and E2, threaded mounting holes
34013-0000-99-3	HSP COMe-mEL10 (E2) SLIM THROUGH	Heatspreader slimline 6.5mm for COMe-mEL10 commercial and E2, through holes

Part Number	Fan Cables	Description
96079-0000-00-0	KAB-HSP 200 mm	Cable adapter to connect fan to module (COMe Basis/Compact/Mini)
96079-0000-00-2	KAB-HSP 40 mm	Cable adapter to connect fan to module (COMe Basis/Compact/Mini)

Part Number	Cooling Solution	Description
34099-0000-99-0	COMe mini Active Uni Cooler (w/o HSP)	Active universal cooler without heatspreader
34099-0000-99-1	COMe mini Passive Uni Cooler (w/o HSP)	Passive universal cooler without heatspreader
34099-0000-99-3	COMe mini Passive Uni Cooler top mount	Passive universal cooler top mountable

3.3. Functional Specification

3.3.1. Block Diagram

Figure 3: Block Diagram COMe-mEL10

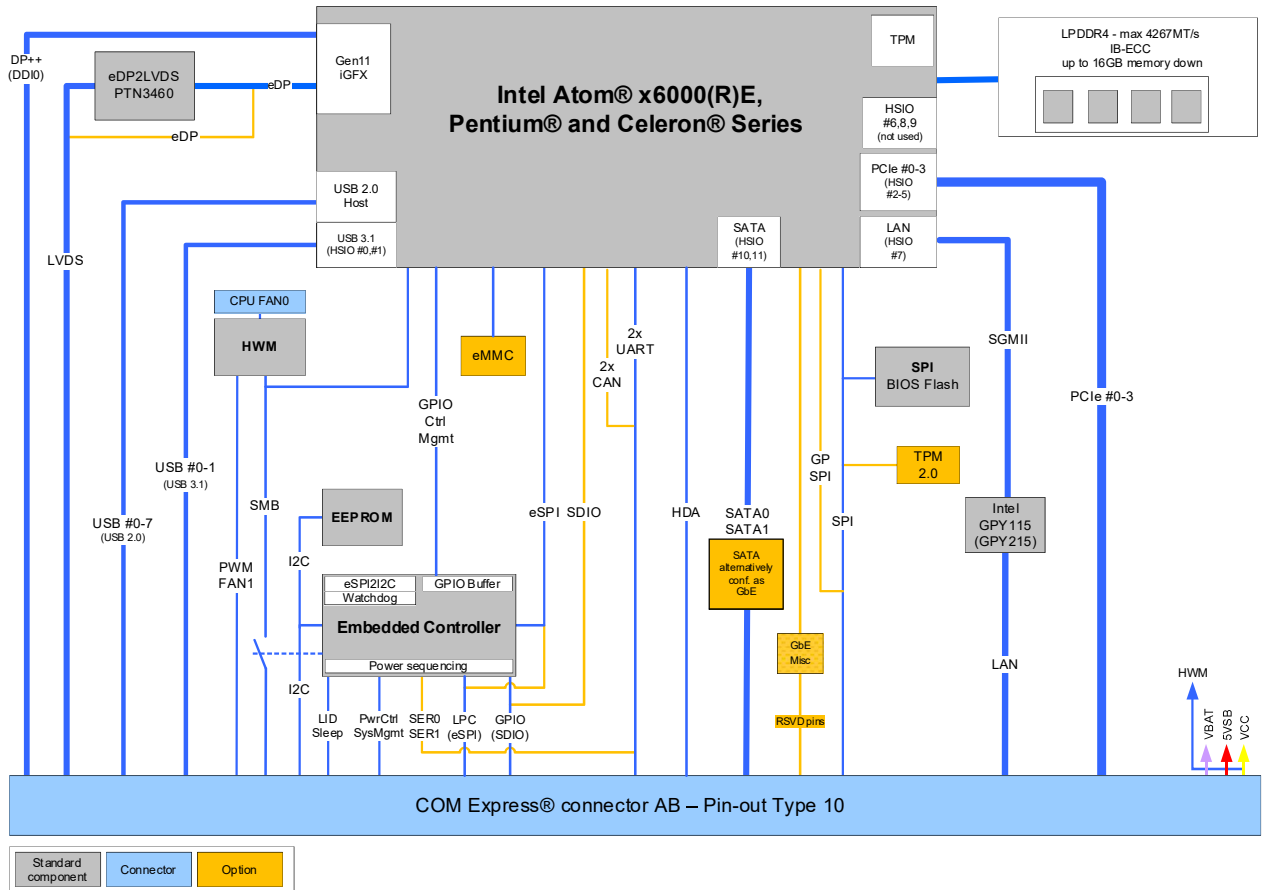

3.3.2. Processors

The COMe-mEL10 is based on the Intel® series of Multi Chip Package (MCP) Atom™ X6000E series, Pentium® and Celeron® processors, with a Platform Controller Hub (PCH) on the same package (compact Type 3 BGA 35 mm x 24 mm package).

The processor variants support the following technologies:

- ▶ Intel® 64 Architecture
- ▶ Intel® Gen 11 GFX graphics
- ▶ Intel® Programmable Service Engine (PSE)
- ▶ Intel® Virtualization Technology (VT-2) with extended pages and (VT-d) for directed I/O
- ▶ Real time computing with Time Coordinated Computing (TCC)
- ▶ Thermal Management with Intel® Thermal Monitor (TM1 and TM2)
- ▶ Power Management with Intel® Speedstep® Technology
- ▶ Security with Intel® Boot Guard device protection, Secure Key and Intel® AES NI

The following table lists the specification of the COMe-mEL10 processor variants.

Table 5: Processor Specification

Intel®	Celeron®	Pentium®	Celeron®	Pentium®	
	J6413	J6426	N6211	N6415	
# of Cores	4	4	2	4	
# of Threads	4	4	2	4	
Cache	1.5 MByte	1.5 MByte	1.5 MByte	1.5 MByte	
Base Frequency	1.8 GHz	2.0 GHz	1.2 GHz	1.2 GHz	
Turbo Frequency (Max.)	3.0 GHz	3.0 GHz	3.0 GHz	3.0 GHz	
Graphic Gen 11 GFX	16 EU	32 EU	16 EU	16 EU	
Thermal Design Power (TDP)	10 W	10 W	6.5 W	6.5 W	
Memory Types/Speed	LPDDR4-3733	LPDDR4-3733	LPDDR4-3200	LPDDR4-3200	
Memory Channels (Max.)	4	4	4	4	
Memory Size (Max.)	16 GB	16 GB	16 GB	16 GB	
ECC Memory	No	No	No	No	
PCIe Express Configurations	4 x1 1x2 + 2 x1 2 x2 1x4	4 x1 1x2 + 2 x1 2 x2 1x4	4 x1 1x2 + 2 x1 2 x2 1x4	4 x1 1x2+ 2 x1 2 x2 1x4	
Max. # PCIe Lanes	4	4	4	4	
Premium IO	Intel®PSE	Intel®PSE	Intel®PSE	Intel®PSE	
Use Condition	PC Client	PC Client	PC Client	PC Client	
Tjunction	Min.	0°C	0°C	0°C	0°C
	Max.	+105°C	+105°C	+105°C	+105°C

Intel®	Atom™	Atom®	Atom®	Atom™	Atom™	Atom™
	X6211E	X6413E	X6425E	X6212RE	X6414RE	X6425RE
# of Cores	2	4	4	2	4	4
# of Threads	2	4	4	2	4	4
Cache	1.5 MByte	1.5 MByte	1.5 MByte	1.5 MByte	1.5 MByte	1.5 MByte
Base Frequency	1.3 GHz	1.5 GHz	2.2 GHz	1.2 GHz	1.5 GHz	1.9 GHz
Turbo Frequency (Max.)	3.0 GHz	3.0 GHz	3.0 GHz	NA	NA	NA
Graphic Gen 11 GFX	16 EU	16 EU	32 EU	16 EU	16 EU	32 EU
Thermal Design Power (TDP)	6 W	9 W	12 W	6 W	9 W	12 W
Memory Types/Speed	LPDDR4-3200	LPDDR4-3200	LPDDR4-3733	LPDDR4-3200	LPDDR4-3200	LPDDR4-4267
Memory Channels (Max.)	4	4	4	4	4	4
Memory Size (Max.)	16 GB	16 GB	16 GB	16 GB	16 GB	16 GB
ECC Memory	In band	In band	In band	In band	In band	In band
PCIe Express Configurations	4 x1 1x2 + 2 x1 2 x2 1x4	4 x1 2 x1 + 1 x2 2 x2 1x4	4 x1 2 x1 + 1 x2 2 x2 1x4	4 x1	4 x1 2 x1 + 1 x2 2 x2 1x4	4 x1 2 x1 + 1 x2 2 x2 1x4

Intel®		Atom™	Atom®	Atom®	Atom™	Atom™	Atom™
		X6211E	X6413E	X6425E	X6212RE	X6414RE	X6425RE
Max. # PCIe Lanes		4	4	4	4	4	4
Premium IO		Intel®PSE	Intel®PSE	Intel®PSE	Intel®PSE/TSN Intel®TCC	Intel®PSE/TSN Intel®TCC	Intel®PSE/TSN Intel®TCC
Use Condition		Embedded	Embedded	Embedded	Industrial	Industrial	Industrial
Tjunction	Min.	-40°C	-40°C	-40°C	-40°C	-40°C	-40°C
	Max.	+105°C	+105°C	+105°C	+110°C	+110°C	+110°C



Use Condition Industrial: Recommended for 24/7 applications.



Use Condition PC Client: within Tjunction limits the max. temperature range during operation is +-70°C starting from boot time temperature.

Use Condition Embedded / Industrial: within Tjunction limits the max. temperature range during operation is +-90°C (+-110°C) starting from boot time temperature.

The behavior is described in Intel document #636112 as DTR = Dynamic Temperature Range. For more information or a higher DTR-value, contact [JUMPtec Support](#).

Find also more information in Intel whitepaper #814861.



The features specified in Table 5: Processor Specification may not be compatible with the COMe-mEL10 features. For specific COMe-mEL10 features, see the relevant section in Chapter 3.3:Functional Specification.

3.3.3. Platform Controller Hub (PCH)

The COMe-mEL10's Multi Chip Package (MCP) includes an integrated Platform Controller Hub (PCH).

3.3.4. System Memory

The COMe-mEL10 supports LPDDR4-4267 memory down with up to four channels supporting 32 Gbit, for a maximum total capacity of 16 GByte for both industrial and commercial temperature graded variants.

The following table lists specific system memory down features.

Type	LPDDR4-4267 / LPDDR4-3200
Memory Densities	16 Gbit, 32 Gbit
Memory Channels	4
Memory Capacity (Max.)	16 GByte
Maximum Speed	4267 MT/s for single rank memory only (system capacity <=8 GByte) 3200 MT/s for dual rank memory only (system capacity >8 GByte)
ECC ^[1]	In band ECC

[1] In-band ECC improves safety and reliability by providing ECC protection to specific regions of the physical memory. Out of band ECC is not supported.



For memory capacities higher than 8 GByte the maximum speed is limited to 3200 MT/s. The maximum speed of 4267 MT/s is only available for single rank memory. Dual rank memory is limited to 3200 MT/s. However, it must be noted that maximum memory speed depends on CPU capability.

3.3.5. Graphics (LVDS or eDP, and DP++)

The COMe-mEL10 supports up to two simultaneous displays on the Digital Display Interface (DDI), where DDIO (port A) is LVDS by default with the option to overlay to eDP requiring a hardware assembly and DDI1 (port B) supports DP++.

The following table lists the display features.

DDI	Display Interface	Description	Max. Resolution
DDIO (port A)	LVDS (default)	Single channel 24-bit color (1 pixel per clock)	1366 x 768 @ 60Hz
	eDP (option)	eDP overlay option requires hardware assembly	4096 x 2160 @ 60Hz
DDI1 (port B)	DP 1.2 V (DP++)	4K resolution with multiple active displays	4096 x 2160 @ 60Hz



Supported Flat panels with Extended Display identification Data (EDID)/DisplayID.



It is recommended to only use a DP-to-HDMI or DP-to-DVI passive adapter compliant to the VESA DP Dual-Mode standard. Display detection issues may occur with use of with FET level shifter adapters for DDC translation.



At 4K resolution, to increase link margin a DP redriver on the carrier is recommended.

3.3.6. HD Audio

The COMe-mEL10 supports HD audio for up to two external codecs.

Type	Intel® HD Audio
# Audio devices	2x external codec



The HD Audio codec frequency is selected in the BIOS setup: PCH-IO Configuration> HD Audio Configuration> HD Audio Advanced Configuration> HD Audio Link Frequency> [6 MHz, 12 MHz, 24 MHz].

3.3.7. PCI Express Lanes [0-3]

The COMe-mEL10 supports up to four high-speed PCI Express 3.0 lanes PCIe [0-3], allowing for the connection of up to four separate external PCIe devices. The default PCIe configuration is (4 x1) with options for (2 x1 + 1 x2), (2 x2) and (1 x4).

The following table lists the supported PCI Express lane configurations.

COMe Connector	HSIO lane	HSIO Port	Supported Lane Configuration			
			4 x1 (default)	1 x2 + 2 x1	2 x2	1 x4
PCIE_0	2	PCle #0	x1	x2	x2	x4
PCIE_1	3	PCle #1	x1			
PCIE_2	4	PCle #2	x1	x2		
PCIE_3	5	PCle #3	x1			

To change the default PCIe configuration (4x1), a new BIOS version is required. For BIOS version information, visit JUMPTec's [Customer Section](#) or contact [JUMPTec Support](#).

3.3.8. USB

The COMe-mEL10 supports two USB 3.1 Gen2 ports backwards compatible with USB 2.0 and six dedicated USB 2.0 ports. The USB Client is an option and if implemented one USB 2.0 port is required to support the USB client functionality. The USB client can be implemented on any USB 2.0 port supporting dual role capabilities. Dynamic changing is not possible. Select the USB 2.0 client port in the BIOS set up and reset the BIOS.

The following table lists the supported USB features.

USB Ports	2x USB 3.1 Gen2 (10 Gb/s) (USB 2.0 backwards compatible) 6x USB 2.0
USB Over Current Signals	4x
USB Client Port	1 x USB 2.0 host/client mode (option)

The following table lists the USB 3.1 port connections.

COMe Connector	HSIO Lane	HSIO Port	Description
USB_SS1	0	USB#0	USB 3.1 Gen 2 (10 Gb/s) dual role port
USB_SS2	1	USB#1	USB 3.1 Gen 2 (10 Gb/s) dual role port



The USB speed can be changed in the BIOS setup menu: Chipset> PCH/IO Configuration> USB Configuration> USB3 Link Speed> GEN1, GEN2.



When designing the carrier board consider the speed of the USB 3.1 Gen 2 (10 Gb/s). It is recommended to use a retimer/redriver on the carrier.



When USB client mode will be used, the carrier board needs to support (10 Gb/s). It is recommended of using a retimer/redriver on the carrier.

The following table lists the USB 2.0 port connections.

COMe Connector	PCH USB Port	Description
USB0	USB2_0	USB 2.0 port

USB1	USB2_1	USB 2.0 port
USB2	USB2_2	USB 2.0 port
USB3	USB2_3	USB 2.0 port
USB4	USB2_4	USB 2.0 port
USB5	USB2_5	USB 2.0 port
USB6	USB2_6	USB 2.0 port
USB7	USB2_7	USB 2.0 port dual role USB Host

3.3.9. SATA

The COMe-mEL10 supports two SATA high-speed storage interface (6 Gb/s) lanes.

The following table lists the SATA connector connections.

COMe Connector	HSIO lane #	HSIO Port	Description
SATA0	10	SATA#0	SATA Gen 3, 6 Gb/s
SATA1	11	SATA #1	SATA Gen 3, 6 Gb/s

3.3.10. Ethernet LAN

The COMe-mEL10 supports one Ethernet port with speeds of 1 Gb/s (with PHY GYP115) or on request up to 2.5 Gb/s (with PHY GPY215).

The main Ethernet PHY features are:

- ▶ Full and half duplex 10Base-T(e), 100Base-T, 1000Base-T and on request 2.5 GBase-T
- ▶ Precise time stamping according to IEEE 1588 V2 and Synchronous Ethernet (SyncE)
- ▶ Smart AZ for legacy MAC to support IEEE 802.3az power saving in idle mode
- ▶ Auto MDI/MDI-X and auto polarity correction
- ▶ Wake on LAN (WOL)
- ▶ Jumbo frame up to 10 KB
- ▶ Auto down for Cat3 (four wire) or bad cable

The following table lists the Ethernet external PHY port connections

COMe Connector	HSIO lane #	HSIO Port	Description
GBE0_MDI[0:3]	7	GBE#0	10/100/1000 Base-T or 2.5 GBase-T



For 2.5 Gb/s Ethernet port speed (requires PHY GPY215 instead of GYP115), Intel® recommends the use of a compatible connector.



Do not use an integrated RJ45 connector module with the center tap shorted together with all 4 pairs at the center-tap transformer. This increases the common mode noise and may create EMI. It is recommend to add a discrete common choke in series with each PHY MDI differential line pairs if this type of integrated connector module (ICM) is chosen.

With PHY GYP115 populated (default) the COM Express signals are as below:

Pin	COMe Signal	Description
A4	GBE0_LINK100#	Ethernet speed LED indicator
A5	GBE0_LINK1000#	

With PHY GP2115 populated (option) the COM Express signals are as below:

Pin	COMe Signal	Description
A4	GBE0_LINK_MID#	Ethernet speed LED indicator
A5	GBE0_LINK_MAX#	

3.3.11. COMe High-speed Serial Interfaces Overview

The COMe-mEL10 supports 12 high-speed serial input output lanes for PCIe Gen 3.0, USB 3.1, SATA and SGMII GBE .

The following table lists the high-speed lane combinations.

HSIO Lane	High-Speed IO				Description
	USB 3.1	PCIe Gen 3.0	GbE	SATA 3.0	
0	USB#0				USB 3.1 Super Speed Gen 2 (10 Gb/s)
1	USB#1				USB 3.1 Super Speed Gen 2 (10 Gb/s)
2		PCIe#0			PCIe 3.0 lane
3		PCIe#1			PCIe 3.0 lane
4		PCIe#2			PCIe 3.0 lane
5		PCIe#3			PCIe 3.0 lane
6					Not connected
7			GbE#0		Onboard GbE (1 Gb/s with GPY115 or optional 2.5 Gb/s with GPY215)
8					Not connected
9					Not connected
10				SATA#0	SATA Gen 3, 6 Gb/s
11				SATA#1	SATA Gen 3, 6 Gb/s

3.3.12. Storage

The COMe-mEL10 support the following storage features.

eMMC	1x eMMC 5.1 NAND Flash (option)
Embedded EEPROM (Eeep)	1x Eeep (EEprom available on address A0h 8-bit/50h 7-bit)

3.3.13. BIOS/Software Features

The following table lists the supported BIOS and software features.

BIOS EFI	AMI Aptio V uEFI
Software	Demo Utility for KEAPI 3.0 usage for all supported OS BIOS/ EFI Flash Utility for EFI shell, Windows 10 and Linux BIOS/EFI Utility to configure PCIe mapping BIOS/EFI Utility for users to implement Boot Logo and customized NVRA
Operating System (OS)	Board Support Packages for: <ul style="list-style-type: none"> ▶ Windows 10 (IOT) Enterprise x64 ▶ Yocto Linux (64 bit) incl. PLD driver and Live-CD ▶ VxWorks 7.x, x64
Custom BIOS Settings/ Flash Backup	Supported

3.3.14. Features

The following table lists General, Special and Optional COMe-mEL10 features.

General Features	
SPI	On-module and external carrier boot from SPI
LPC	LPC bus (default) pins shared with eSPI (eSPI overlay on request)
LID Signal	Supported
Sleep Signal	Supported
SM Bus	supported
Fast I2C	Connected to module EEPROM, carrier EEPROM and RTC clock
Watchdog Support	Dual staged
RTC	Internal RTC (with external RTC on request)
Display (DDI)	Up to 4k resolutions

Special Features	
Temperature Grade	Industrial grade temperature
Embedded API	KEAPI 3.0 (included in reference image)

Optional Features	
eMMC Flash	eMMC 5.1
eDP instead of LVDS	LVDS signals can be overlaid with eDP signals
eSPI instead of LPC	eSPI instead of LPC on the COM connector
UART	2x RX/TX from embedded controller instead of CPU
USB Client	1x USB Client
TPM 2.0	Dedicated TPM chip

3.4. Electrical Specification

The module powers on by connecting to a carrier board via the COMe interface connector. Before connecting the module to the carrier board, ensure that the carrier board is switch off and disconnected from the main power supply at the time of connection. Failure to disconnect the main power supply from the carrier board could result in personal injury and damage to the module and/or carrier board. The COMe interface connector pins on the module limits the amount of power received.

⚠ CAUTION

The module powers on by connecting to the carrier board using the interface connector. Before connecting the module's interface connector to the carrier board's corresponding connector, ensure that the carrier board is switch off and disconnected from the main power supply. Failure to disconnect the main power supply could result in personal injury and damage to the module and/or carrier board.

⚠ CAUTION

Observe that only trained personnel aware of the associated dangers connect the module, within an access controlled ESD-safe workplace.

3.4.1. Power Supply Specification

The COMe-mEL10 supports a supply voltage of 12 V (single power rail voltage) and a wide input voltage range of 4.75 V to 20 V. Other supported voltages are 5 V standby and 3.3 V RTC battery input.

Table 6: COMe-mEL10 Electrical Specification

Supply Voltage (VCC) (range)	4.75 V to 20 V
Supply Voltage (VCC) (nominal)	12 V
Standby Voltage	5 V \pm 5 % Note: 5V Standby voltage is not mandatory for operation
RTC Voltage	2.8 V to 3.47 V

⚠ CAUTION

Only connect to an external power supply delivering the specified input rating and complying with the requirements of Safety Extra Low Voltage (SELV) and Limited Power Source (LPS) of UL/IEC 60950-1 or (PS2) of UL/IEC 62368-1.

NOTICE

To protect external power lines of peripheral devices, make sure that the wires have the right diameter to withstand the maximum available current and the enclosure of the peripheral device fulfils the fire-protection requirements of IEC/EN 62368-1.

NOTICE

If any of the supply voltages drops below the allowed operating level longer than the specified Hold-up time, all the supply voltages should be shut down and left OFF for a time long enough to allow the internal board voltages to discharge sufficiently.
If the OFF time is not observed, parts of the board or attached peripherals may work incorrectly or even suffer a reduction of MTBF. The minimum OFF time depends on the implemented PSU model and other electrical factors and must be measured individually for each case.

3.4.1.1. Power Supply Voltage Rise Time

The input voltage rise time is 0.1 ms to 20 ms from input voltage $\leq 10\%$ to nominal input voltage. To comply with the ATX specification there must be a smooth and continuous ramp of each DC input voltage from 10 % to 90 % of the DC input voltage final set point.

3.4.1.2. Power Supply Voltage Ripple

The maximum power supply voltage ripple and noise is 200 mV peak-to-peak measured over a frequency bandwidth of 0 MHz to 20 MHz. The voltage ripple, must not cause the input voltage range to be exceeded.

3.4.1.3. Power Supply Inrush Current

The maximum inrush current at 5 V standby is 2 A. From states G3 (Module is mechanically completely off, with no power consumption) or S5 (module appears to be completely off) to state S0 (module is fully usable) the maximum inrush current meets the SFX Design Guide.

3.4.2. Power Management

The COMe-mEL10 implements the Advanced Configuration and Power Interface (ACPI) 6.0 hardware specification with features such as power button and suspend states. The Power management options are available within the BIOS set up menu: **Advance>ACPI Settings>**.

3.4.2.1. Suspend States

If power is removed, 5 V can be applied to the V_5V_STBY pins to support the ACPI suspend-states:

- ▶ Suspend to RAM (S3)
- ▶ Suspend-to-Disk (S4)
- ▶ Soft-off state (S5)



If power is removed, the wake-up event (S0) requires 12 V VCC to power on the module.

3.4.2.2. Power Supply Control Settings

Power supply control settings are set in the BIOS and enable the module to shut down, rest and wake from standby.

Table 7: Power Supply Control Settings

COMe Signal	Pin	Description
Power Button (PWRBTN#)	B12	A PWRBTN# falling edge signal creates power button event ($50 \text{ ms} \leq t < 4 \text{ s}$, typical 400 ms) at low level). Power button events can be used to bring a system out of S5 soft-off and other suspend states, as well as powering the system down. Pressing the power button for at least four seconds turns off power to the module Power Button Override
Power Good (PWR_OK)	B24	Indicates that all power supplies to the module are stable within specified ranges. PWR_OK signal goes active and module internal power supplies are enabled.

COMe Signal	Pin	Description
		PWR_OK can be driven low to prevent module from powering up until the carrier is ready and releases the signal. PWR_OK should not be deactivated after the module enters S0 unless there is a power fail condition.
Reset Button (SYS_RESET#)	B49	When the "SYS_RESET#" pin is detected active (falling edge triggered), it allows the processor to perform a "graceful" reset, by waiting up to 25 ms for the SMBus to enter the idle state before forcing a reset, even though activity is still occurring. Once reset is asserted, it remains asserted for 5 ms to 6 ms regardless of whether the SYS_RESET# input remains asserted or not.
Carrier Board Reset(CB_Reset#)	B50	When the "CB_Reset" from module to carrier is active low, the module outputs a request to the carrier board to reset.
SM-Bus Alert (SMB_ALERT#)	B15	When an external battery manager is present and SMB_ALERT # connected, the module always powers on even if the BIOS switch "After Power Fail" is set to "Stay Off".
Battery low (BATLOW#)	A27	BATLOW# Indicates that the external battery is low and provides a battery-low signal to the module for orderly transitioning to power saving or power cut-off ACPI modes.
Wake Up Signal WAKE[0:1]	B66/ B67	Indicates PCIe wake up signal "Wake 0" or general purpose wake up signal "Wake 1"
Suspend Control (SUS_STAT#)	B18	SUS_STAT# indicates an imminent suspend operation. Used to notify LPC devices.



After a complete power loss (including battery voltage), there is an additional cold reset. This additional reset will not happen on any subsequent warm or cold reboots.

3.4.3. Power Supply Modes

The COMe-mEL10 supports single power supply mode and ATX power supply mode. To change the power supply mode set the ATX mode and single power supply mode setting as described in the following chapters.

3.4.3.1. ATX Power Supply Mode

To start the module in ATX mode, connect VCC and 5V Standby from a ATX PSU. As soon as the standby rail ramps up the PCH enters the S5 state and starts the transition to S0. SUS_S3# (usually connected to PSU PS_ON#) turns on the main power rail (VCC). As soon as the PSU indicates that the power supply is stable (PWR_OK high) the PCH continues the transition to S0. The input voltage must always be higher than 5V standby (VCC>5VSB) for modules supporting a wide input voltage range down to 4.75V.



The input voltage must always be higher than 5 V standby (VCC>5VSB) for modules supporting a wide input voltage range down to 4.75 V.

Table 8: ATX Mode Settings

State	PWRBTN#	PWR_OK	V5_Standby	PS_ON#	VCC
G3	x ^[1]	x ^[1]	0V	x ^[1]	0V
S5	high	low	5V	high	0V

S5 → S0	PWRBTN Event	low → high	5V	high →	0V → VCC
S0	high	high	5V	low	VCC

^[1] Defines that there is no difference if connected or open.

3.4.3.2. Single Power Supply Mode

To start the module in single power supply mode, connect VCC power and open PWR-OK at the high level. VCC can be 4.75 V to 20 V. To power on the module from S5 state, press the power button or reconnect VCC.



Suspend/Standby states are not supported in single power supply mode.

Table 9: Single Power Supply Mode Settings

State	PWRBTN#	PWR_OK	V5_Standby	VCC
G3	0V/x ^[1]	0V/x ^[1]	0V/x ^[1]	0V/x ^[1]
S5	high	open / high	open	VCC
S5 → S0	PWRBTN Event	open / high	open	reconnecting VCC
G3 → S0	high	open / high	open	connecting VCC

^[1] Defines that there is no difference if connected or open.



All ground pins must be connected to the carrier board's ground plane.

3.5. Thermal Management

3.5.1. Heatspreader Plate Assembly and Metal Heat Slug

A heatspreader plate (HSP) assembly is NOT a heat sink. The heatspreader plate works as a COM Express® standard thermal interface to be used in conjunction with a heat sink or external cooling devices. External cooling must be provided to maintain the heatspreader plate at proper operating temperatures. Under worst-case conditions, the cooling mechanism must maintain an ambient air and heatspreader plate temperature on any spot of the heatspreader's surface according to the module specifications:

- ▶ 60°C for commercial temperature grade modules
- ▶ 85°C for industrial temperature grade modules (E2)

Commercial temperature grade variants have no preconfigured Intel® heatspreader and the supplied metal heat slug (packed separately in the delivery box for the heatspreader) must be installed.

Industrial temperature grade variants have a preconfigured Intel® heatspreader and do not require the metal heat slug to be installed.



For industrial temperature grade variants the multi-chip package comes with a preconfigured heatspreader and the supplied metal heat slug is not required.

3.5.2. Active/Passive Cooling Solutions

Both active and passive thermal management approaches can be used with the heatspreader plate. The optimum cooling solution depends on the COM Express® application and environmental conditions. The active or passive cooling solutions are designed to cover the power and thermal dissipation for a commercial temperature range used in housing with a suitable airflow. For more information concerning possible cooling solutions, see Table 4: Accessories.

3.5.3. Operating with the Heatspreader Plate (HSP) Assembly

The operating temperature requirements are:

- ▶ Maximum ambient temperature with ambient being the air surrounding the module
- ▶ Maximum measurable temperature on any part on the heatspreader's surface

Table 10: Heatspreader Temperature Specification

Temperature Grade	Requirements
Commercial Grade	at 60°C HSP temperature on MCP @ 100% load needs to run at nominal frequency
Industrial Grade (E2)	at 85°C HSP temperature the MCP @ 50% load is allowed to start throttling for thermal protection

3.5.4. Operating without the Heatspreader Plate (HSP) Assembly

The operating temperature is the maximum measurable temperature on any spot on the module's surface.

3.5.5. Temperature Sensors

The thermal resistor (Figure 4, pos. 2) measures the Multi Chip Package (MCP) temperature. The thermal resistor is not capable of measuring very fast rises and falls in temperature and measurements may show a certain non-linearity. The thermal resistor gives a general indication of the ambient temperature close to the MCP. When comparing the thermal resistor value to the internal MCP values (i.e. DTS based values) differences are expected. These differences are due to the design and are not to be considered as an error. The MCP's temperature is referred to as CPU temperature in the BIOS set up menu: **Advanced>H/W Monitor> Reference Temperature**.

The on-module Hardware Monitor (HWM) chip uses an on-chip temperature sensor to measure the module's temperature and is referred to as module temperature in the BIOS set up menu: **Advanced>H/W Monitor> Reference Temperature**. The HWM uses the SMBus interface, see Table 20: SMBus Address.

Figure 4: Module Temperature Sensors



1 HWM measure the modules temperature

2 RT1- thermal resistor measures the MCP temperature

3.5.6. On-Module Fan Connector

The fan connector powers, controls and monitors an external fan. To connect a standard 3-pin connector fan to the module, use a fan cable, see Table 4: Accessories.

Figure 5: Fan Connector 3-Pin



1 3-pin fan connector

Table 11: Fan Connector (3-Pin) Pin Assignment

Pin	Signal	Description	Type
1	Fan_Tach_IN#	Fan input voltage from COMe connector	Input
2	V_FAN	12 V \pm 10% (max.) across module input range	PWR
3	GND	Power GND	PWR

If the input voltage is below or equal to 13 V, then the maximum supply current to the on-module fan connector is 350 mA. The maximum supply current is reduced to 150 mA if the input voltage to the module is between 13 V and 20 V.

NOTICE

Always check the fan specification according to the limitations of the supply current and supply voltage.

3.6. Environmental Specification

The COMe-mEL10 supports two temperature grades commercial and Industrial (E2). The industrial temperature grade modules support an integrated heatspreader. For temperature grade information, see Chapter 2.1: Module Variants.

Table 12: Temperature Grades and Humidity Specification

Temperature Grades	Operating	Non-operating (Storage)
Commercial Grade	0°C to +60°C (32°F to 140°F)	-30°C to +85°C (-22°F to 185°F)
Industrial Grade (E2)	-40°C to +85°C (-40° to 185°F)	-40°C to +85°C (-40°F to 185°F)
Relative Humidity	93 % , at +40°C, non-condensing	

3.7. Standards and Certifications

The COMe-mEL10 complies with the following standards and certificates. If modified, the prerequisites for specific approvals may no longer apply. For more information, contact [JUMPTec Support](#).

Table 13: Standards and Certifications

EMC		
Emission	EN 55032 Class B CISPR32	Electromagnetic compatibility of multimedia equipment - Emission requirements
Immunity	IEC / EN 61000-6-2	Electromagnetic compatibility (EMC) Part 6-2: Generic standards - Immunity standard for industrial environments

Safety		
Europe	EN 62368-1	Safety for audio/video and information technology equipment
USA & Canada	UL 62368-1/CSA 62368-1 (Component Recognition)	Recognized by Underwriters Laboratories Inc. Representative samples of this component have been evaluated by UL and meet applicable UL requirements. UL listings: AZOT2.E147705 AZOT8.E147705

Environment		
Shock	IEC / EN 60068-2-27	Non-operating shock test (half-sinusoidal, 11 ms, 15 g)
Vibration	IEC / EN 60068-2-6	Non-operating vibration (sinusoidal, 10 Hz – 2000 Hz, +/- 0.15 mm, 2 g)
RoHS II	Directive 2011/65/EU incl. 2015/863/EU	Restriction of Hazardous Substances in electrical and Electronic Equipment (RoHS)

3.7.1. MTBF

The MTBF (Mean Time Before Failure) values were calculated using a combination of the manufacturer's test data, (if available) and the Telcordia (Bellcore) issue 2 calculations for the remaining parts.

The Telcordia calculation used is "Method 1 Case 3" in a ground benign, controlled environment. This particular method takes into account varying temperature and stress data and the system is assumed to have not been burned-in. Other environmental stresses (such as extreme altitude, vibration, salt-water exposure) lower MTBF values.

Table 14: MTBF

MTBF
System MTBF (hour) = 513232 h @ 40°C for COMe-mEL10 J6426 Reliability report article number: 34012-0432-J2-4
System MTBF (hour) = 508437 h @ 40°C for COMe-mEL10 E2 x6425RE Reliability report article number: 34013-0832-R2-4



The MTBF estimated value assumes no fan, but a passive heat sinking arrangement. Estimated RTC battery life (as opposed to battery failures) is not accounted for and needs to be considered separately. Battery life depends on both temperature and operating conditions. When the module is connected to external power, the only battery drain is from leakage paths.

Figure 6 shows MTBF de-rating values for the commercial temperature range when used in an office or telecommunications environment. Other environmental stresses (extreme altitude, vibration, salt-water exposure, etc.) lower MTBF values.

Figure 6: MTBF De-rating Values

COMe-mEL10 J6426

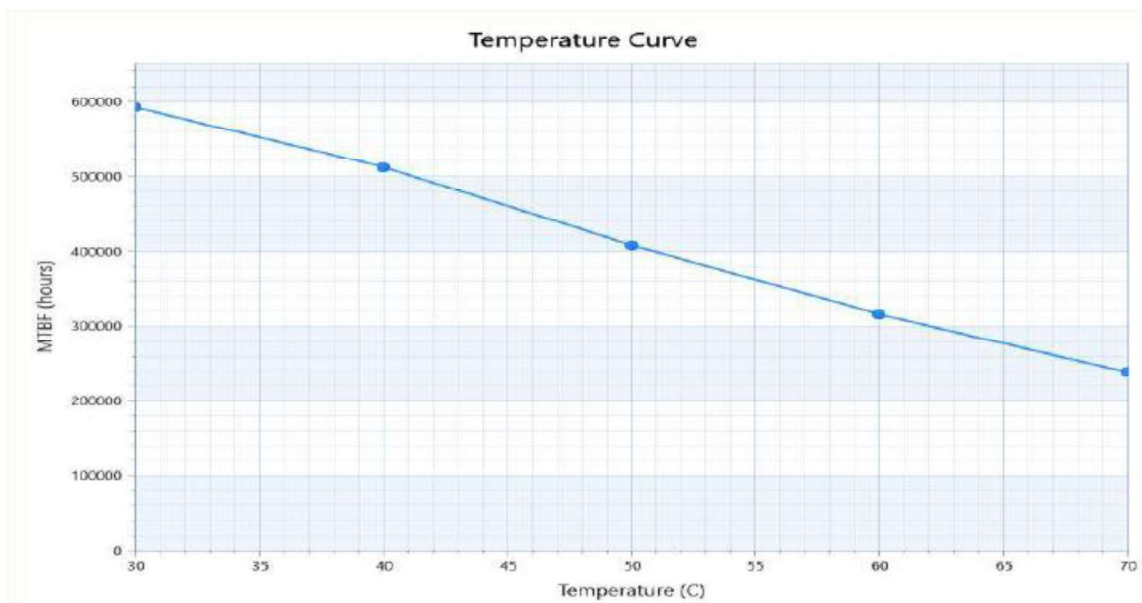

COMe-mEL10 E2 x6425RE

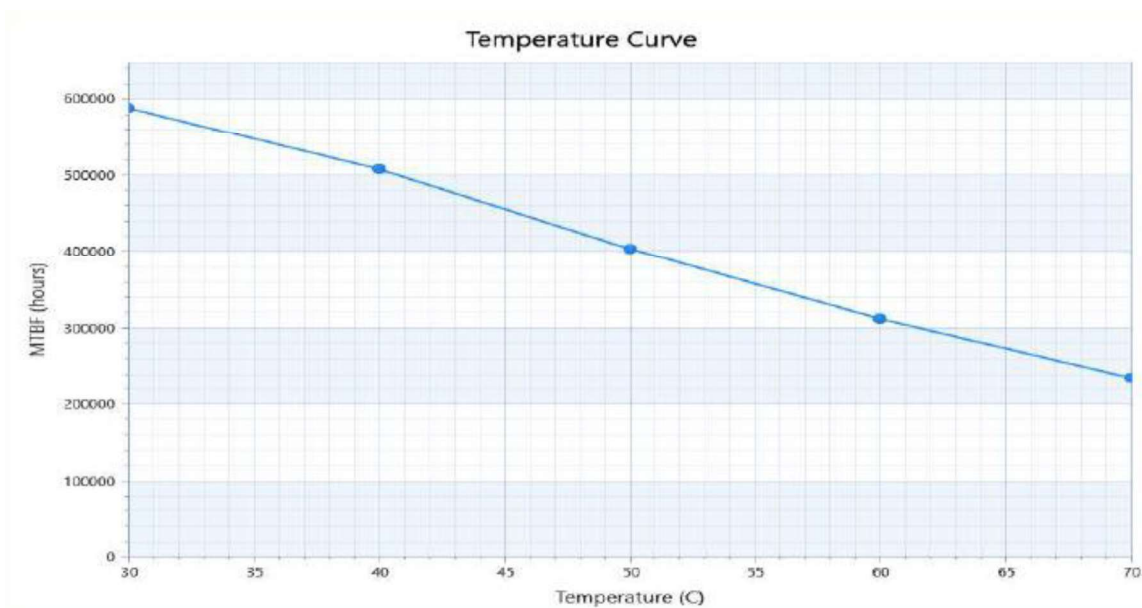

3.8. Mechanical Specification

The COMe-mEL10 is compliant with the COM Express® PICMG COM.0 Rev 3.0 mechanical specification.

3.8.1. Module Dimensions

The mini module dimensions are 84 mm x 55 mm (3.3" x 2.17").

Figure 7: Module Dimensions

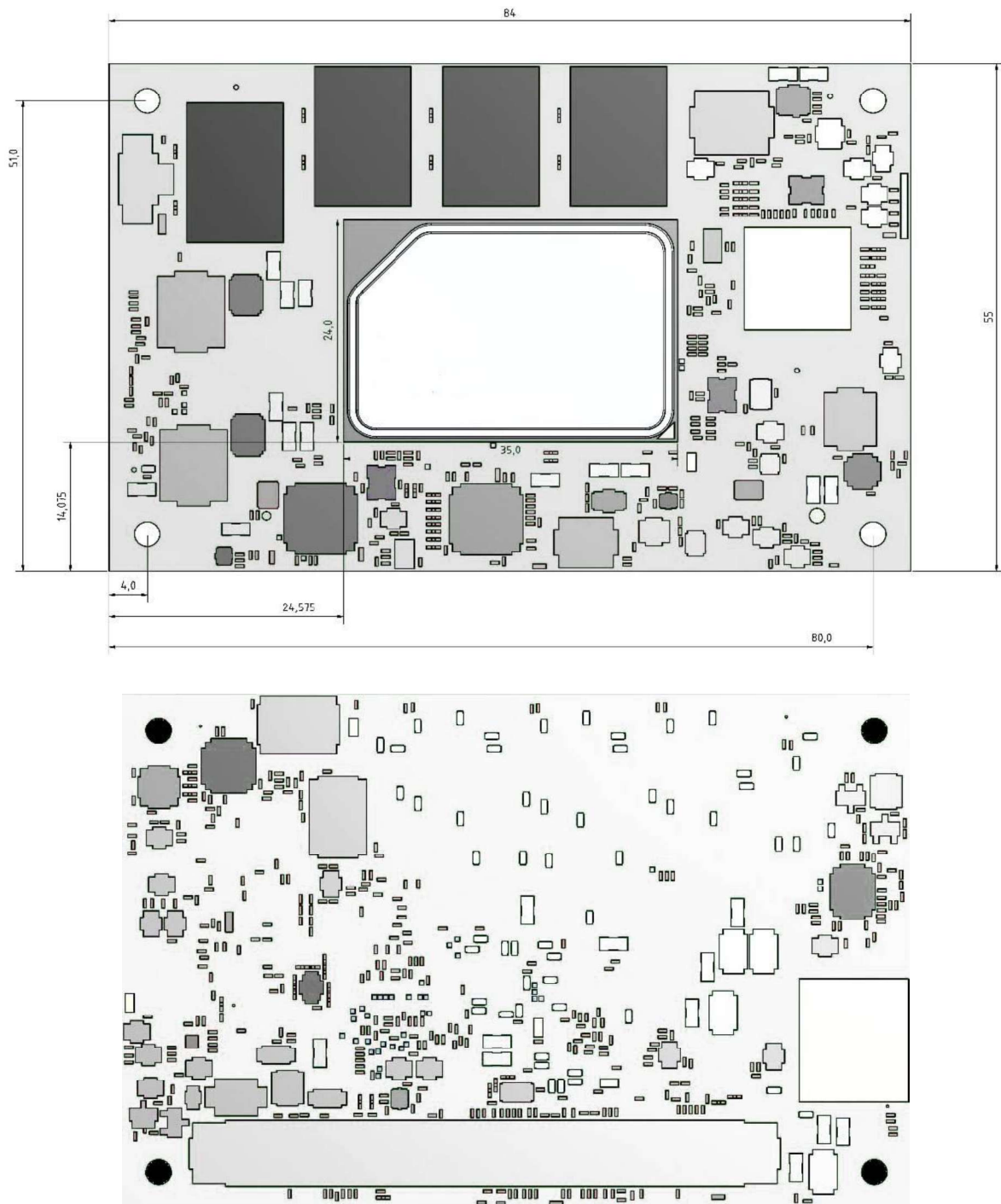

*All dimensions are in mm.

3.8.2. Module Height

The COM Express® specification defines a module height of approximately 13 mm, when measured from the bottom of the module's PCB board, to the top of the heatspreader, see Figure 8.

The overall height of the module and carrier board depends on the implemented cooling solution. The height of the cooling solution is not specified in the COMe specification.

Figure 8: Module and Carrier Height

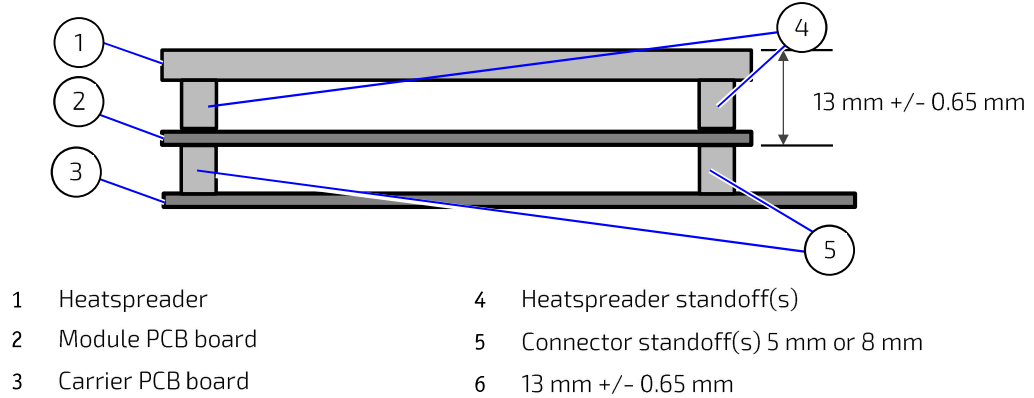

3.8.3. Metal Heat Slug Dimensions

The metal heat slug 35 mm x 24 mm (1.38" x 0.94") is located on top of the multi-chip package.

Figure 9: Metal Heat Slug Dimensions

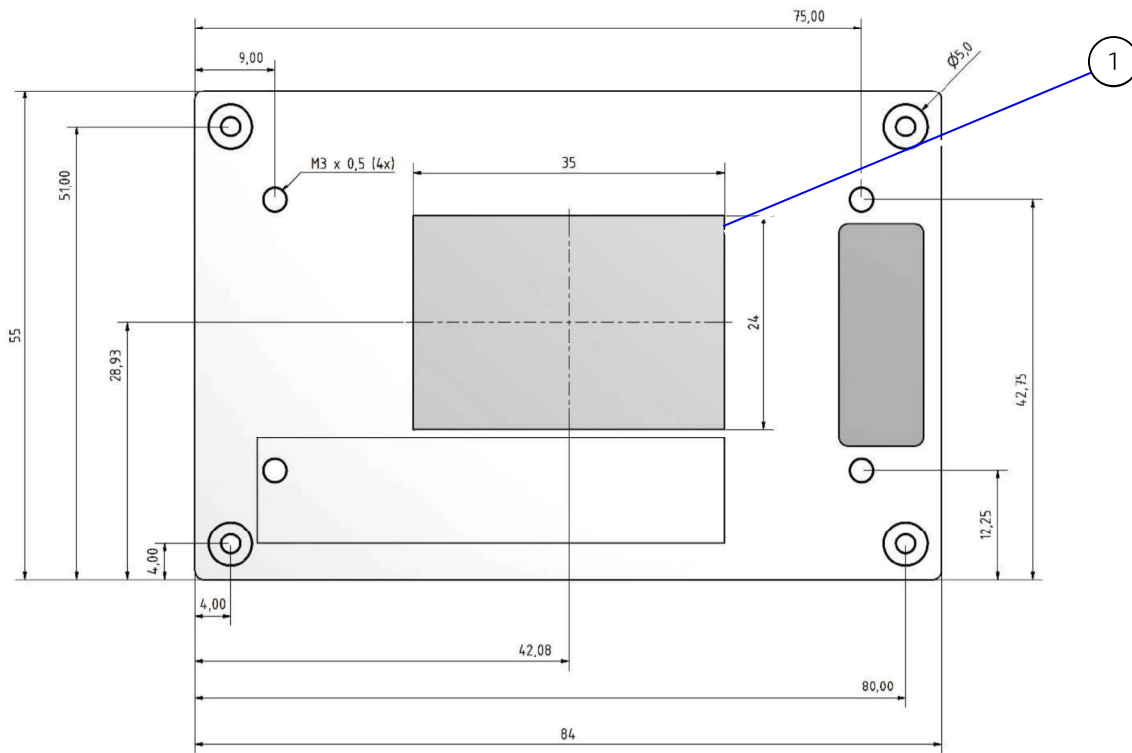

*All dimensions shown in mm.

1 Metal heat slug

4/ Features and Interfaces

4.1. ACPI Power States

ACPI enables the system to power down and save power when not required (suspend) and wake up when required (resume). The ACPI controls the power states S0–S5, where S0 has the highest priority and S5 the lowest priority.

The COMe-mEL10 supports ACPI 6.0 and the power states S0, S3, S4, S5 only.



Not all ACPI defined power states are available.
Systems that support the low-power idle state do not use power states S1.

Table 15: Supported Power States Function

S0	Working state
S3	ACPI suspend to RAM state
S4	Suspend-to-disk/Hibernate
S5	Soft-off state

To power on from states S3, S4 and S5 use:

- ▶ Power Button
- ▶ WakeOnLAN (S3, S4)

4.2. eMMC Flash Memory (option)

The Embedded Multimedia Flash Card (eMMC) is eMMC 5.1 compatible.

eMMCs are available as MLC = Multi-Level-Cell or TLC = Triple-Level-Cell.

In order to improve reliability, endurance and performance eMMCs can be re-configured as pSLCs = pseudo Single-Level-Cell.

eMMCs are available with a maximum capacity of 256GB as TLC. Higher capacities can be expected in the future. Reconfiguring to pSLC reduces the eMMC capacity.

The standard COMe-mEL10 variants support MLC eMMC.

On request, other eMMC capacities or configurations can be offered.



Pseudo SLC (pSLC) memory is a reconfigured MLC/TLC eMMC.
 MLC to pSLC: the capacity is half of a MLC memory.
 TLC to pSLC: the capacity is a third of the TLC memory.

4.3. eSPI Mode (option)

The eSPI interface is pin shared with LPC Interface signals to switch from one interface to another, a hardware modification in the form of additional resistors is required. The module's signal ESPI_EN# on pin B47 indicates whether eSPI-mode or LPC-mode is enabled/disabled. The LPC interface is the default connection to COMe connector.

In eSPI mode "ESPI_EN#" connects to ground on the carrier. The module uses pull-up resistors on this signal to detect the mode.



If ESPI_EN# selection on the carrier does not match the module configuration (eSPI/LPC) the module is unable to boot.

4.4. Fast I2C

The fast I2C bus transfer data between components on the same module with transfers at up to 400 kHz clock speeds.

The I2C controller supports:

- ▶ Multi-master transfers
- ▶ Clock stretching
- ▶ Collision detection
- ▶ Interruption on completion of an operation

To change the I2C bus speed, in the BIOS setup menu select:

Advanced>Miscellaneous>I2C Speed> 400 kHz to 1 kHz

The default speed is 200 kHz.

4.5. GPIO

The eight GPIO pins support four inputs pins (A54 for GPIO, A63 for GPI1, A67 for GPI2 and A85 for GPI3) and four output pins (A93 for GPO0, B54 for GPO1, B57 for GPO2 and B63 for GPO3) by default. The four GPI [0-3] pins are pulled high with a pull-up resistor (e.g. 100 K ohms) and the four GPO [0-3] pins are pulled low with a pull-down resistor (e.g. 100 K ohms) on the module.

To change the default GPIO signal-state users are required to make BIOS and/or OS-driver changes, and additional hardware changes by adding external termination resistors on the carrier board to override the weak on-module pull-up resistors with a lower resistance pull-down (e.g. 10 K ohms), or pull-down resistors with a lower resistance pull-up (e.g. 10 K ohms).

The COMe-mEL10's GPIO pins are pin shared with SDIO pins. GPIO is the default and SDIO an option supported using the processor. Hardware assembly defines whether the shared pins are GPIO or SDIO. There is no BIOS or software option to change the shared pins.



Configuration must be performed using the OS driver.

4.6. Hardware Monitor (HWM)

The Hardware Monitor (HWM) Nuvoton NCT7802Y controls the health of the module by monitoring critical aspects such as the module's processor temperature using thermal resistors, power supply voltages and fan speed for cooling.

The SMART FAN™ technology controls the duty cycle of the fan output (FAN_PWMOUT) with temperature setting points. This enables flexible fan control for cooling solutions and noise sensitive solutions. For system protection, users can set threshold values for alarm signals.

The HWM is accessible via the System Management (SM) Bus address 5Ch, see Chapter 5.2: System Management (SM) Bus.



The HMW bus address is 5Ch.

4.7. LPC

The Low Pin Count (LPC) interface is pin shared with eSPI. The LPC is the default connection to the COMe connector. The signal pin B47 (ESPI_EN#) indicates whether ESPI-mode or LPC-mode is enabled/disabled.

In LPC mode "ESPI_EN#" is not connected on the carrier. The module uses pull-up resistors on this signal to detect the mode.



If ESPI_EN# selection on the carrier does not match the module configuration (eSPI/LPC) the module is unable to boot.

The LPC low speed interface can be used for peripheral circuits such as an external Super I/O controller that typically combines legacy-device support into a single IC. The implementation of this subsystem complies with the COM Express® Specification. For more information, refer to the COM Express® Design Guide maintained by PICMG or the official PICMG documentation.

The LPC bus does not support DMA (Direct Memory Access). When more than one device is used on LPC, a zero delay clock buffer is required that can lead to limitations for the ISA bus.

For LPC Super I/O, additional BIOS implementations are necessary, contact [JUMPtEC Support](#).

4.8. Intel® PSE

The Intel® Programmable Service Engine (PSE) is a dedicated offload engine for IoT functions such as embedded controller, low DMIP computing, network proxy, out-of-band device management, network proxy, real-time and sensor hub.

The COMe-mEL10 supports Intel® PSE. For more information, see Table 5: Processor Specification.

4.9. Intel® TCC

Intel® Time Coordinate Computing (TCC) improves the time synchronization performance and the timeless (also known as real-time) performance by providing a common timekeeping framework, making it possible for software to calculate the precise time between numerous systems.

The COMe-mEL10 supports Intel® TCC on industrial grade modules. For more information, see Table 5: Processor Specification.

4.10. Real Time Clock

The RTC keeps track of the current time accurately. The RTC's low power consumption means that the RTC can be powered from an alternative source of power enabling the RTC to continue to keep time while the primary source of power is off or unavailable.

The RTC's battery voltage range is 2.8 V to 3.47 V. Typical RTC values are 3 V and less than 10 μ A. If the module is powered by mains supply, the RTC voltage is generated by on-module regulators, to reduce RTC current draw.

The COMe-mEL10 supports an internal RTC by default with the option for an external RTC on request.



Using the COMe-mEL10 without RTC battery voltage supply may result in improper behavior. Contact [JUMPTec Support](#) in case you plan a carrier design without RTC battery.

4.11. SDIO (option)

The SDIO features is supported from the processor. To find out more about SDIO, contact [JUMPTec Support](#).

4.12. Serial Peripheral Interface (SPI)

The Serial Peripheral Interface (SPI) bus is a synchronous serial data link where devices communicate in master/slave mode, where the master device initiates the data frame. Multiple slave devices are allowed with individual slave select (chip select) lines.



The SPI interface may only be used with a SPI Flash device to boot from the external BIOS on the carrier board.



General purpose SPI connected to COMe instead of boot SPI requires a hardware modification in the form of additional resistors. Implemented on request only.

4.12.1. SPI Boot

The SPI Flash chip stores the BIOS to be booted. The COMe-mEL10 supports SPI boot from the 32 MByte SPI Flash chip on the module and an external 32 MByte SPI Flash chip on a carrier board. The pins A34 (BIOS_DIS0#) and pin B88 (BIOS_DIS1#) select the SPI Flash boot source, see Table 16: SPI Boot Pin Configuration.



The SPI flash chip on the carrier is required to be 32MByte (256MBit).

Table 16: SPI Boot Pin Configuration

BIOS_DIS0#	BIOS_DIS1#	Boot Bus	Function
Open	Open	SPI	Boot on-module SPI
Open	GND	SPI	Boot carrier board SPI



The BIOS cannot be split between two chips. Booting takes place either from the on-module SPI Flash chip or the external SPI Flash chip on the carrier board.

Table 17: Supported SPI Boot Flash Types:

Size	Manufacturer	Part Number	Device ID
32MB	Winbond	W25Q256JV	EFh / 40h / 19h

32MB	Macronix	MX25L25645GZ2I	C2h / 20h / 19h
32MB	Micron	MT25QL256ABA1EW9-0SIT	20h / 8Ah / 19h
32MB	Cypress	S25FL256LAGNFI010	01h / 60h / 19h

4.12.2. Booting the SPI Flash Chip

Initially, the EFI Shell is booted with an USB key containing the binary used to flash the on-module SPI Flash chip. To program the external SPI Flash chip on the carrier board with the BIOS binary, use an external programmer.



Register for JUMPtec's [Customer Section](#) to get access to BIOS downloads and PCN service.

To boot either the carrier board or on-module SPI flash chip, perform the following:

1. Connect a SPI flash with the correct size (similar to BIOS binary (*.BIN) file size) to the carrier SPI interface.



The external SPI flash chip on the carrier is required to be 32MByte (256MBit).

2. Open pin A34 (BIOS_DIS0#) and connect pin B88 (BIOS_DIS1#) to ground to enable the external SPI Flash chip to boot on carrier SPI or ground pin A34 (BIOS_DIS0#), and open pin B88 (BIOS_DIS1#) to enable SPI Flash chip to boot on-module SPI.

4.12.3. External SPI Flash Boot on Modules with Intel® Management Engine

When booting from the external SPI Flash on the carrier board if the COM Express® module is exchanged for another module of the same type, the Intel® Management Engine (ME) will fail during the next start. The Management Engine (ME) binds itself to every module it has previously flashed which in the case of an external SPI Flash is the module present when flashed.

To avoid this issue, after changing the COM Express® module for another module, conduct a complete flash from the external SPI Flash device. If disconnecting and reconnecting the same module again, this step is not necessary.

4.13. TPM 2.0

The Trusted Platform Module (TPM) 2.0 technology stores RSA encryption keys specific to the host system for hardware authentication

Each TPM contains an RSA key pair called the Endorsement Key (EK). The pair is maintained inside the TPM and cannot be accessed by software. The Storage Root Key (SRK) is created when a user or administrator takes ownership of the system. This key pair is generated by the TPM based on the Endorsement Key and an owner-specified password.

A second key, called an Attestation Identity Key (AIK) protects the device against unauthorized firmware and software modification by hashing critical sections of firmware and software before they are executed. When the system attempts to connect to the network, the hashes are sent to a server that verifies they match the expected values. If any of the hashed components have been modified since the last start, the match fails, and the system cannot gain entry to the network.

The COMe-mEL10 supports firmware TPM (fTPM) using the integrated TPM 2.0 capability of the Intel Platform Trusted Technology (Intel® PTT). Hardware TPM is an option.

4.14. UART

The UART serial communications interface option supports up to two serial RX/TX ports defined in the COMe specification on pins A98 (SERO_TX) and A99 (SERO_RX) for UART0, and pins A101 (SER1_TX) and A102 (SER1_RX) for UART1.

By default the UARTs are driven by the CPU.

Optionally (build option) the UARTs can be driven by the embedded controller.

4.15. Watchdog Timer (WTD) Dual Stage

The watchdog timer interrupt is a hardware or software timer implemented by the module to the carrier board if there is a fault condition in the main program; the watchdog triggers a system reset or other corrective actions after a specific time, with the aim to bring the system back from a non-responsive to normal state.

The COMe-mEL10 supports an independently programmable watchdog that works with two stages that can be used stage by stage.

Table 18: Dual Staged Watchdog Timer- Time-Out Events

0000b	No action	Stage is off and will be skipped
0001b	Reset	Restarts the module and starts a new POST and operating system
0101b	Delay -> No action	Might be necessary when an operating system must be started and the time for the first trigger pulse must be extended. Only available in the first stage!
1000b	WDT Only	Triggers WDT pin on the carrier board connector (COM Express® pin B27) only
1001b	Reset + WDT	
1101b	DELAY + WDT -> No action	

4.15.1. Watchdog Timer Signal

The watchdog interrupt (WDT) on the COM Express® connector's pin B27 indicates a Watchdog time-out event. The WDT signal is configurable to any of the two stages. For more details, contact [JUMPttec Support](#).

5/ System Resources

5.1. I2C Bus

The following table specifies the devices connected to the accessible I2C bus including the I2C address. The I2C bus is available at the COM Express® connector pin A83, I2C_CK and pin A84, I2C_DAT.

Table 19: I2C Bus Port Address

8-bit Address	7-bit Address	Used For	Available	Description
58h	2Ch	Internally reserved	No	
A0h	50h	Module EEPROM	YES	
AEh	57h	Carrier board EEPROM	Optional	
64h	32h	External RTC	Optional	

5.2. System Management (SM) Bus

The 8-bit SMBus address uses the LSB (bit 0) for the direction of the device.

- ▶ Bit0 = 0 defines the write address
- ▶ Bit0 = 1 defines the read address

The following table specifies the 8-bit and 7-bit SMBus write address for all devices.

Table 20: SMBus Address

8-bit Address	7-bit Address	Device	Description
5Ch	2Eh	HWM NCT7802Y	Hardware Monitor. Do not use this address for external devices under any circumstances!

6/ COMe Interface Connector

The COMe interface connector (X1A) mounted on the bottom side of the module contains 220-pins with two rows where row A contains pins A1 to A110 and row B contains pins B1 to B110.

Figure 10: COMe Interface Connector

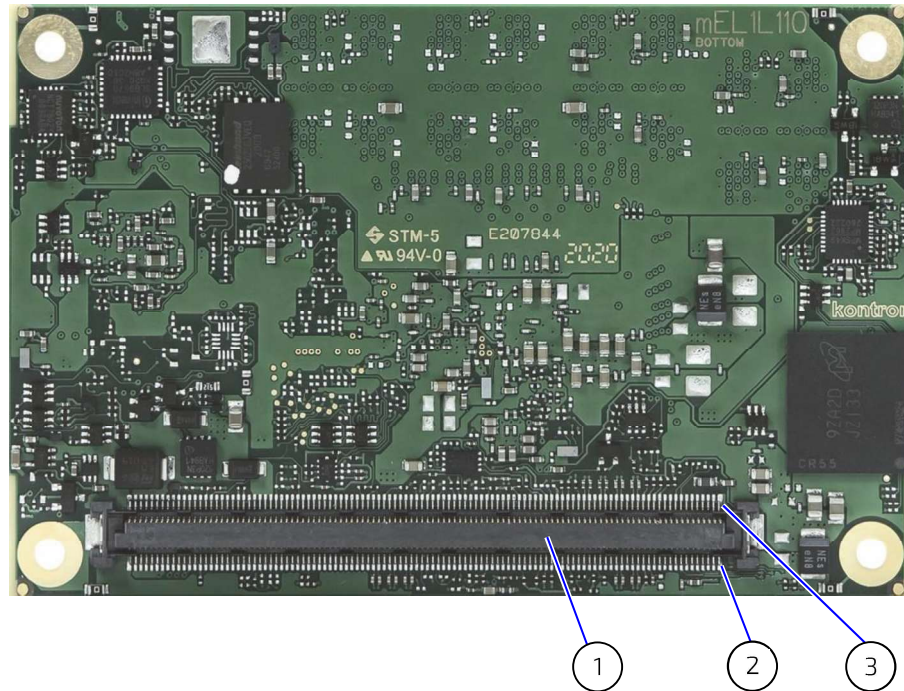

- | | | | |
|---|--------------------------------|---|-------------|
| 1 | COMe interface connector (X1A) | 3 | X1A, Pin B1 |
| 2 | X1A, Pin A1 | | |

6.1. Connecting COMe Interface Connector to Carrier Board

The COMe interface connector (X1A), is inserted into the corresponding connector on the carrier board and secured using the mounting points and standoffs. The height of the standoffs (either 5 mm or 8 mm) depends on the height of the carrier board's connector.

⚠ CAUTION

The module is powered on by connecting to the carrier board using the interface connector. Before connecting the module's interface connector to the carrier board's corresponding connector, ensure that the carrier board is switch off and disconnected from the main power supply. Failure to disconnect the main power supply could result in personal injury and damage to the module and/or carrier board.

Observe that only trained personnel aware of the associated dangers connect the module, within an access controlled ESD-safe workplace.

NOTICE

To protect external power lines of peripheral devices, make sure that: the wires have the right diameter to withstand the maximum available current. The enclosure of the peripheral device fulfills the fire-protection requirements of IEC/EN 62368.

6.2. X1A Signals

The terms used in the connector pin assignment tables and a description of the signal type can be found in Table 21: General Signal Description. If additional information is required refer to the Appendix at the end of this user guide and the PICMG specification COM.0 Rev 3.0 Type 10 standard.



The information provided under **type, module terminations and comments** is complimentary to the COM.0 Rev 3.0 Type 10 standard. For more information, contact [JUMPtEC Support](#)

Table 21: General Signal Description

Type	Description	Type	Description
NC	Not Connected (on this product)	O-1.8	1.8 V Output
I/O-3,3	Bi-directional 3.3 V I/O-Signal	O-3,3	3.3 V Output
I/O-5T	Bi-dir. 3.3 V I/O (5 V Tolerance)	O-5	5 V Output
I/O-5	Bi-directional 5V I/O-Signal	DP-I/O	Differential Pair Input/Output
I-3,3	3.3 V Input	DP-I	Differential Pair Input
I/OD	Bi-directional Input/Output Open Drain	DP-O	Differential Pair Output
I-5T	3.3 V Input (5 V Tolerance)	PU	Pull-Up Resistor
OA	Output Analog	PD	Pull-Down Resistor
OD	Output Open Drain	PDS	Pull-Down-Strap
+ and -	Differential Pair Differentiator	PWR	Power Connection
		PWR GND	Power Ground Connection

6.3. COMe Interface Connector (X1A) Pin Assignment

The following tables list the pin assignment of the 220-pin COMe interface connector X1A (Row A1 to A110) and (Row B1 to B110).

6.3.1. Connector X1A Row A1 - A110

Table 22: Connector X1A Row A1 to A110 Pin Assignment

Pin	COMe Signal	Description	Type	Termination	Description
A1	GND	Power Ground	PWR GND		
A2	GBE0_MDI3-	Ethernet Media Dependent Interface 3	DP-I/O		
A3	GBE0_MDI3+				
A4	GBE0_LINK100#/ GBE0_LINK_MID#	Ethernet speed LED indicator, depends on PHY populated (see chapter 2.3.10)	OD		
A5	GBE0_LINK1000#/ GBE0_LINK_MAX#				
A6	GBE0_MDI2-	Ethernet Media Dependent Interface 2	DP-I/O		
A7	GBE0_MDI2+				
A8	GBE0_LINK#	Ethernet link LED indicator (LED)	OD		
A9	GBE0_MDI1-	Ethernet Media Dependent Interface 1	DP-I/O		
A10	GBE0_MDI1+				
A11	GND	Power Ground	PWR GND		
A12	GBE0_MDI0-	Ethernet Media Dependent Interface 0	DP-I/O		
A13	GBE0_MDI0+				
A14	GBE0_CTREF	Center Tab Reference Voltage	0		100 nF capacitor to GND
A15	SUS_S3#	Indicates Suspend to RAM (or deeper)	0-3.3	PD 10 k Ω	
A16	SATA0_TX+	SATA transmit data pair 0	DP-0	AC Coupled on Module	
A17	SATA0_TX-				
A18	SUS_S4#	Indicates Suspend to Disk (or deeper) state	0-3.3	PD 10 k Ω	
A19	SATA0_RX+	SATA receive data pair 0	DP-I	AC Coupled on Module	
A20	SATA0_RX-				
A21	GND	Power Ground	PWR GND		
A22	USB_SSRX0-	USB super speed receive data pair 0	DP-I		
A23	USB_SSRX0+				
A24	SUS_S5#	Indicates system is in Soft Off state	0-3.3	PD 10 k Ω	
A25	USB_SSRX1-	USB super speed receive data pair 1	DP-I		
A26	USB_SSRX1+				
A27	BATLOW#	Provides a battery-low signal to the module to indicate external battery is low	I-3.3	PU 10 k Ω , 3.3 V (S5)	Assertion prevents wake from S3-S5 state
A28	ATA_ACT#	Serial ATA activity LED indicator	OD-3.3	PU 10 k Ω , 3.3 V (S0)	Can sink 15 mA
A29	HDA_SYNC	HD Audio Sync	0-3.3		
A30	HDA_RST#	HD Audio Reset	0-3.3		
A31	GND	Power Ground	PWR GND		
A32	HDA_CLK	HD Audio Bit Clock Output	0-3.3		
A33	HDA_SDOOUT	HD Audio Serial Data Out	0-3.3		

Pin	COMe Signal	Description	Type	Termination	Description
A34	BIOS_DIS0#	BIOS selection straps 0	I-3.3	PU 10 k Ω , 3.3 V (S5)	
A35	THRMTRIP#	Thermal Trip indicates CPU has entered thermal shutdown	O-3.3 OD	PU 10 k Ω , 3.3 V (S0)	Thermal trip event transition to S5 indicator
A36	USB6-	USB 2.0 data differential pair port 6	DP-I/O	PD 14.25 K Ω to 14.8 k Ω in PCH	
A37	USB6+				
A38	USB_6_7_OC#	USB overcurrent indicator port 6/7	I-3.3	PU 10 k Ω , 3.3 V (S5)	
A39	USB4-	USB 2.0 data differential pair port 4	DP-I/O	PD 14.25 K Ω to 14.8 k Ω in PCH	
A40	USB4+				
A41	GND	Power Ground	PWR GND		
A42	USB2-	USB 2.0 data differential pair port 2	DP-I/O	PD 14.25 K Ω to 14.8 k Ω in PCH	
A43	USB2+				
A44	USB_2_3_OC#	USB overcurrent indicator port 2/3	I-3.3	PU 10 k Ω , 3.3V (S5)	
A45	USB0-	USB 2.0 data differential pairs port 0	DP-I/O	PD 14.25 K Ω to 14.8 k Ω in PCH	
A46	USB0+				
A47	VCC_RTC	Real Time Clock (RTC) circuit power input	PWR 3V		Voltage range 2.8 V to 3.47 V
A48	RSVD	Reserved for future use	NC		
A49	GBE0-SDP	Gigabit Ethernet Controller 0 Software-Definable pin	I/O-3.3	PD 10 k Ω	
A50	LPC_SERIRQ /	Serial interrupt request /	I/OD-3.3 /	PU 8.2 k Ω , 3.3 V (S0) / -	
	ESPI_CS1#	eSPI master Chip select 1	O-1.8		
A51	GND	Power Ground	PWR GND		
A52	RSVD	Reserved for future use	NC		
A53	RSVD				
A54	GPI0	General purpose input 0	I-3.3	PU 100 k Ω , 3.3 V (S0)	Option SD_DATA0
A55	RSVD	Reserved for future use	NC		
A56	RSVD				
A57	GND	Power Ground	PWR GND		
A58	PCIE_TX3+	PCI Express transmit lane 3	DP-0	AC Coupled on Module	
A59	PCIE_TX3-				
A60	GND	Power Ground	PWR GND		
A61	PCIE_TX2+	PCI Express transmit lane 2	DP-0	AC Coupled on Module	
A62	PCIE_TX2-				
A63	GPI1	General purpose input 1	I-3.3	PU 100 k Ω , 3.3 V (S0)	Option SD_DATA1
A64	PCIE_TX1+	PCI Express transmit lane 1	DP-0	AC Coupled on Module	
A65	PCIE_TX1-				
A66	GND	Power Ground	PWR GND		
A67	GPI2	General purpose input 2	I-3.3	PU 100 k Ω , 3.3 V (S0)	Option SD_DATA2
A68	PCIE_TX0+	PCI Express transmit lane 0	DP-0		

Pin	COMe Signal	Description	Type	Termination	Description
A69	PCIE_TX0-			AC Coupled on Module	
A70	GND	Power Ground	PWR GND		
A71	LVDS_A0+	LVDS channel A DAT0 or EDP Lane 2 transmit	DP-0		Optional EDP_TX2+
A72	LVDS_A0-				Optional EDP_TX2-
A73	LVDS_A1+	LVDS channel A DAT1 or EDP Lane 1 transmit	DP-0		Optional EDP_TX1+
A74	LVDS_A1-				Optional EDP_TX1-
A75	LVDS_A2+	LVDS channel A DAT2 or EDP Lane 0 transmit	DP-0		Optional EDP_TX0+
A76	LVDS_A2-				Optional EDP_TX0-
A77	LVDS_VDD_EN	LVDS or EDP panel power control	0-3.3	PD 100 k Ω	Optional EDP_VDD_EN
A78	LVDS_A3+	LVDS channel A DAT3	DP-0		
A79	LVDS_A3-				
A80	GND	Power Ground	PWR GND		
A81	LVDS_A_CK+	LVDS channel A clock or EDP lane 3 transmit	DP-0		Clock 20 MHz to 80 MHz
A82	LVDS_A_CK-				Option EDP_TX3-
A83	LVDS_I2C_CK	LVDS I2C Clock for (DDC) / eDP AUX +	I/O-3.3	PU 2.2 k Ω , 3.3 V (S0)	Optional EDP_AUX+
A84	LVDS_I2C_DAT	LVDS I2C Data (DDC) / eDP AUX -	I/O-3.3	PU 2.2 k Ω , 3.3 V (S0)	Optional EDP_AUX-
A85	GPI3	General purpose input 3	I-3.3	PU 100 k Ω 3.3V (S0)	Option SD_DATA3
A86	RSVD	Reserved for future use	NC		
A87	eDP_HPD	Detection of Hot Plug / Unplug	I-3.3	PD 400 k Ω LVDS / 100 k Ω EDP	
A88	PCIE_CK_REF+	Reference PCI Express Clock for all PCI Express and PCI Express Graphics lanes	DP-0		100 MHz
A89	PCIE_CK_REF-				
A90	GND	Power Ground	PWR GND		
A91	SPI_POWER	3.3 V Power Output for external SPI Flash	0-3.3		100 mA maximum
A92	SPI_MISO	Data in to module from carrier SPI (SPI Master IN Slave Out)	I-3.3		
A93	GPO0	General purpose output 0	0-3.3	PD 100 k Ω	Optional SD_CLK
A94	SPI_CLK	SPI clock Clock from Module to Carrier SPI	0-3.3		
A95	SPI_MOSI	SPI master Out Slave In Data out from Module to Carrier SPI	0-3.3		
A96	TPM_PP	TPM physical presence	I-3.3	PD 4.7 k Ω	TMP does not use this functionality
A97	TYPE10#	Indicates to Carrier Board that type 10 module is installed	PDS	PD 47 k Ω	
A98	SER0_TX	Serial port 0 TXD	0-3.3		20 V protection circuit implemented on-module, PD on carrier boards needed for proper operation
A99	SER0_RX	Serial port 0 RXD	I-5T	PU 47 k Ω , 3.3 V (S0)	20 V protection circuit implemented on-module
A100	GND	Power Ground	PWR GND		

Pin	COMe Signal	Description	Type	Termination	Description
A101	SER1_TX	Serial port 1 TXD	0-3.3		20 V protection circuit implemented on-module, PD on carrier boards needed for proper operation
A102	SER1_RX	Serial port 1 RXD	I-5T	PU 47 k Ω , 3.3 V (S0)	20 V protection circuit implemented on-module
A103	LID#	LID switch input	I-3.3	PU 47 K Ω , 3.3 V (S5)	
A104	VCC_12V	Main input voltage (4.75 V to 20 V)	PWR 4.75 V to 20 V		
A105	VCC_12V				
A106	VCC_12V				
A107	VCC_12V				
A108	VCC_12V				
A109	VCC_12V				
A110	GND	Power Ground	PWR GND		

+ and - Differential pair differentiator

6.3.2. Connector X1A Row B1 – B110

Table 23: Connector X1A Row B1 to B110 Pin Assignment

Pin	COMe Signal	Description	Type	Termination	Description
B1	GND	Power Ground	PWR GND		
B2	GBE0_ACT#	Ethernet Controller activity LED indicator	OD		
B3	LPC_FRAME# / ESPI_CS0	Indicates start of LPC Frame	0-3.3 / 0-18		
B4	LPC_AD0 / ESPI_IO_0	LPC multiplexed command, address and data bus 0 / eSPI Master data I/O 0	I/O-3.3	PU 20 K Ω 3.3 V (S0)	PU only for LPC option
			1/0-18		
B5	LPC_AD1 / ESPI_IO_0	LPC multiplexed command, address and data bus 1 / eSPI Master data I/O 1	I/O-3.3	PU 20 K Ω 3.3 V (S0)	
B6	LPC_AD2 / ESPI_IO_2	LPC multiplexed command, address and data bus 2 / eSPI Master data I/O 2	I/O-3.3	PU 20 K Ω 3.3 V (S0)	
B7	LPC_AD3 / ESPI_IO_3	LPC multiplexed command, address and data bus 3 / eSPI Master data I/O 3	I/O-3.3 /	PU 20 K Ω 3.3 V (S0)	
B8	LPC_DRQ0# / ESPI_ALERT0	LPC serial DMA master request	I-3.3 / I-18	PU10 K Ω 3.3 V / PU 1 k Ω 1.8 V	LPC DMA request not supported
B9	LPC_DRQ1# / ESPI_ALERT1		I-3.3 / I-18		
B10	LPC_CLK / ESPI_CK	LPC 25 MHz clock output	0-3.3 / 0-18		25 MHz (LPC) 20 MHz (eSPI)
B11	GND	Power Ground	PWR GND		

Pin	COMe Signal	Description	Type	Termination	Description
B12	PWRBTN#	Power Button event	I-3.3	PU 10 k Ω , 3.3 V (S5)	Brings a system out of S5 soft-off and other suspend states, and powers the module down.
B13	SMB_CLK	SMBus clock line	O-3.3	PU 10 k Ω 3.3 V (S5)	
B14	SMB_DAT	SMBus bidirectional data line	I/O-3.3	PU 3.74 k Ω 3.3 V (S5)	
B15	SMB_ALERT#	SMBus alert generates a SMI# or wakes the system	I-3.3	PU 10 k Ω , 3.3 V (S5)	
B16	SATA1_TX+	SATA transmit data pair 1	DP-0	AC Coupled on Module	
B17	SATA1_TX-				
B18	SUS_STAT# /	Suspend status /	O-3.3 /	PD 10 k Ω /	Notifies LPC devices of imminent suspend / -
	ESPI_RESET	eSPI Reset	O-1.8	PD 76.8 k Ω	
B19	SATA1_RX+	SATA receive data pair 1	DP-1	AC Coupled on Module	
B20	SATA1_RX-				
B21	GND	Power Ground	PWR GND		
B22	USB_SSTX0-	USB super speed transmit pair 0	DP-0		
B23	USB_SSTX0+				
B24	PWR_OK	Power OK from main power supply	I-5T	PU 51 k Ω , 3.3 V	20 V protection circuit implemented on module
B25	USB_SSTX1-	USB super speed transmit pair 1	DP-C		
B26	USB_SSTX1+				
B27	WDT	Indicates watchdog time-out event has occurred	O-3.3	PD 10 k Ω	
B28	HDA_SDIN2	Audio Codec serial data input 2	I-3.3	NC	Not supported
B29	HDA_SDIN1	Audio Codec serial data input 1	I-3.3		
B30	HDA_SDIN0	Audio Codec serial data input 0	I-3.3		
B31	GND	Power Ground	PWR GND		
B32	SPKR	Speaker output provides the PC beep signal and is mainly intended for debugging purposes	O-3.3	PD 20 k Ω in PCH	PD is removed after reset is de-asserted
B33	I2C_CLK	I2C port clock output	O-3.3	PU 2.21 k Ω 3.3 V (S5)	
B34	I2C_DAT	I2C port data I/O line	I/O-3.3		
B35	THRM#	Input from off-module temp sensor indicating an over-temp situation	I-3.3	PU 10 k Ω , 3.3 V (S0)	
B36	USB7-	USB 2.0 differential data pairs port 7	DP-I/O	PD 14.25 k Ω to 24.8 k Ω	
B37	USB7+				
B38	USB_4_5_OC#	USB overcurrent indicator port 4/5	I-3.3	PU 10 k Ω , 3.3 V (S5)	
B39	USB5-	USB 2.0 differential data pairs port 5	DP-I/O	PD 14.25 k Ω to 24.8 k Ω	
B40	USB5+				
B41	GND	Power Ground	PWR GND		
B42	USB3-	USB 2.0 differential data pairs port 3	DP-I/O	PD 14.25 k Ω to 24.8 k Ω	
B43	USB3+				
B44	USB_0_1_OC#	USB overcurrent indicator port 0/1	I-3.3	PU 10 K Ω , 3.3 V (S5)	

Pin	COMe Signal	Description	Type	Termination	Description
B45	USB1-	USB 2.0 differential data pairs port 1	DP-I/O	PD 14.25 k Ω to 24.8 k Ω	
B46	USB1+				
B47	ESPI_EN#	Enable/disable ESPI-mode/LPC-mode	I-3.3	PU 10 k Ω 3.3 V (S5)	
B48	USB0_HOST_PRSENT	USB Host present on USB0	I-3.3	PD 100 K Ω	
B49	SYS_RESET#	Reset button input	I-3.3	PU 10 k Ω , 3.3 V (S5)	
B50	CB_RESET#	Carrier board reset	O-3.3	PD 10K Ω	Resets output from module to carrier board
B51	GND	Power Ground	PWR GND		
B52	RSVD	Reserved for future use	NC		
B53	RSVD				
B54	GPO1	General purpose output 1	O-3.3	PD 100 k Ω	Optional SD_CMD
B55	RSVD	Reserved for future use	NC		
B56	RSVD				
B57	GPO2	General purpose output 2	O-3.3	PD 100 K Ω	Optional SD_WP
B58	PCIE_RX3+	PCI Express receive lane 3	DP-I		
B59	PCIE_RX3-				
B60	GND	Power Ground	PWR		
B61	PCIE_RX2+	PCI Express receive lane 2	DP-I		
B62	PCIE_RX2-				
B63	GPO3	General purpose output 3	O-3.3	PD 100 K Ω	Optional SD_CD#
B64	PCIE_RX1+	PCI Express receive lane 1	DP-I		
B65	PCIE_RX1-				
B66	WAKE0#	PCI Express Wake Event, wake up signal	I-3.3	PU 10 K Ω , 3.3 V (S5)	
B67	WAKE1#	General purpose Wake Event	I-3.3	PU 10 K Ω , 3.3 V (S5)	Implement on PS2 keyboard or mouse
B68	PCIE_RX0+	PCI Express receive lane 0	DP-I		
B69	PCIE_RX0-				
B70	GND	Power Ground	PWR GND		
B71	DDIO_PAIR0+	DDIO data pair 0	DP-0		
B72	DDIO_PAIR0-				
B73	DDIO_PAIR1+	DDIO data pair 1	DP-0		
B74	DDIO_PAIR1-				
B75	DDIO_PAIR2+	DDIO data pair 2	DP-0		
B76	DDIO_PAIR2-				
B77	DDIO_PAIR4+	DDIO data pair 4	NC		Not supported
B78	DDIO_PAIR4-				
B79	LVDS/BKLT_EN	LVDS /EDP panel backlight enable (ON)	O-3.3	PD 100 k Ω	Optional EDP_BKLT_EN
B80	GND	Power Ground	PWR GND		
B81	DDIO_PAIR3+	DDIO data pair 3	DP-0		
B82	DDIO_PAIR3-				
B83	LVDS/BKLT_CTRL	LVDS / EDP panel backlight brightness control	O-3.3		Optional EDP_BKLT_CTRL

Pin	COMe Signal	Description	Type	Termination	Description
B84	VCC_5V_SBY	5V Standby	PWR 5 V (S5)		Optional, not necessary in single supply mode
B85	VCC_5V_SBY				
B86	VCC_5V_SBY				
B87	VCC_5V_SBY				
B88	BIOS_DIS1#	BIOS selection strap to determine BIOS boot device	I-3.3	PU 10 K Ω , 3.3 V (S5)	
B89	DDO_HPD	DDIO hot plug detect	I-3.3	PD 100 k Ω	
B90	GND	Power Ground	PWR GND		
B91	DDIO_PAIR5+	DDIO data pair 5	NC		Not supported
B92	DDIO_PAIR5-				
B93	DDIO_PAIR6+	DDIO data pair 6	NC		Not supported
B94	DDIO_PAIR6-				
B95	DDIO_DCC_AUX_SEL	DDIO DCC/ Aux select	I-3.3	PD 1 M Ω	
B96	USB_HOST_PRSENT	USB host preset on USB7	I-3.3	PD 100 k Ω	
B97	SPI_CS#	Chip select for carrier board SPI	0-3.3		
B98	DDIO_CTRLCLK_AUX+	DDIO auxiliary clock control signal	I/O-3.3	PD 100 k Ω	PU 2.2 k Ω if DCC is selected
B99	DDIOCTRLDATA_AUX-	DDIO auxiliary data control signal	I/O-3.3	Pu 100 k Ω , 3,3V (S0)	
B100	GND	Power Ground	PWR GND		
B101	FAN_PWMOUT	Fan speed control by PWM Output	0-3.3		20 V protection circuit implemented on module, PD on carrier board needed for proper operation.
B102	FAN_TACHIN	Fan tachometer input for fan with a two-pulse output	I-3.3	PU 47 k Ω , 3.3 V (S0)	20 V protection circuit implemented on module
B103	SLEEP#	Sleep button signal used by ACPI operating system to bring system to sleep state or wake it up again	I-3.3	PU 47 k Ω , 3.3 V (S5)	
B104	VCC_12V	Main input voltage (4.75 V-20 V)	PWR 4.75 V to 20 V		
B105	VCC_12V				
B106	VCC_12V				
B107	VCC_12V				
B108	VCC_12V				
B109	VCC_12V				
B110	GND	Power Ground	PWR GND		

+ and - Differential pair differentiator

7/ UEFI BIOS

7.1. Starting the UEFI BIOS

The COMe-mAS10 (E2) uses a JUMPTec–customized, pre-installed and configured version of AMI Aptio® V BIOS based on the Unified Extensible Firmware Interface (UEFI) specification and the Intel® Platform Innovation Framework for EFI.

The UEFI BIOS provides a variety of new and enhanced functions specifically tailored to the hardware features of the COMe-mAS10 (E2).



This chapter provides an overview of the BIOS and its setup. A more detailed listing and description of all BIOS setup nodes can be found in the BIOS file package available on our [Customer Section](#). Please register there to get access to BIOS downloads and Product Change Notifications.

The UEFI BIOS comes with a Setup program that provides quick and easy access to the individual function settings for control or modification of the default configuration. The Setup program allows access to various menus resp. sub-menus that provide the specific functions.

To start the UEFI BIOS Setup program, follow the steps below:

1. Power on the board
2. Wait until the first characters appear on the screen (POST messages or splash screen)
3. Press the key
4. If the UEFI BIOS is password-protected, a request for password will appear. Enter either the User Password or the Supervisor Password (see Security Setup Menu), press <RETURN>, and proceed with step 5.
5. The Setup menu appears

7.2. Navigating the UEFI BIOS

The COMe-mAS10 (E2) UEFI BIOS Setup program uses a hot key navigation system. The hot key legend bar is located at the bottom of the Setup screens. The following table provides a list of navigation hot keys available in the legend bar.

Table 24: Navigation Hot Keys Available in the Legend Bar

Sub-screen	Description
<F1>	<F1> key invokes the General Help window
<->	<Minus> key selects the next lower value within a field
<+>	<Plus> key selects the next higher value within a field
<F2>	<F2> key loads previous values
<F3>	<F3> key loads optimized defaults
<F4>	<F4> key Saves and Exits
<←> or <→>	<Left/Right> arrows selects major Setup menus on menu bar, for example, Main or Advanced
<↑> or <↓>	<Up/Down> arrows select fields in the current menu, for example, Setup function or sub-screen
<ESC>	<ESC> key exits a major Setup menu and enters the Exit Setup menu Pressing the <ESC> key in a sub-menu displays the next higher menu level

Sub-screen	Description
<RETURN>	<RETURN> key executes a command or selects a submenu

7.3. Setup Menus

The Setup utility features a selection bar at the top of the screen that lists the menus.



Figure 11: Setup Menu Selection Bar

The Setup menus available for the COMe-mEL10 are:

- ▶ Main
- ▶ Advanced
- ▶ Security
- ▶ Boot
- ▶ Save & Exit

The currently active menu and the currently active UEFI BIOS Setup item are highlighted in white. Use the left and right arrow keys to select the Setup menus.

Each Setup menu provides two main frames. The left frame displays all available functions. Configurable functions are displayed in blue. Functions displayed in grey provide information about the status or the operational configuration.

7.4. Getting Help

The right frame displays a Help window providing an explanation of the respective function.

7.5. UEFI Shell

The JUMPTec UEFI BIOS features a built-in and enhanced version of the UEFI Shell. For a detailed description of the available standard shell scripting, refer to the EFI Shell User Guide. For a detailed description of the available standard shell commands, refer to the EFI Shell Command Manual. Both documents can be downloaded from the EFI and Framework Open Source Community homepage:

<http://sourceforge.net/projects/efi-shell/files/documents/>



JUMPTec UEFI BIOS does not provide all shell commands described in the EFI Shell Command Manual.

7.5.1. Entering the UEFI Shell

To enter the UEFI Shell, follow the steps below:

1. Power on the board
2. Press the <F7> key (instead of) to display a choice of boot devices
3. Select 'UEFI: Built-in EFI shell'

```

UEFI Interactive Shell v2.2
EDK II / JUMPTec add-on v0.3
UEFI v2.80 (American Megatrends, 0x0005001A)
map: No mapping found.

```

4. Press the <ESC> key within 5 seconds to skip startup.nsh or any other key to continue
The output produced by the device-mapping table can vary depending on the board's configuration
If the <ESC> key is pressed before the 5 second timeout elapses, the shell prompt is shown:

```
Shell>
```

7.5.2. Exiting the UEFI Shell

To exit the UEFI Shell, follow one of the steps below:

- ▶ Use the *exit* UEFI Shell command to select the boot device, in the Boot menu, that the OS boots from
- ▶ Reset the board using the *reset* UEFI Shell command
- ▶ Press the reset button of the board or power down/up the board

7.6. UEFI Shell Scripting

7.6.1. Startup Scripting

If the <ESC> key is not pressed and the timeout has run out then the UEFI Shell automatically tries to execute some startup scripts. It searches for scripts and executes them in the following order:

1. Initially searches for JUMPTec flash-stored startup script.
2. If there is no JUMPTec flash-stored startup script present, then the UEFI-specified **startup.nsh** script is used. This script must be located on the root of any of the attached FAT formatted disk drive.
3. If none of the startup scripts are present or the startup script terminates then the default boot order is continued.

7.6.2. Create a Startup Script

Startup scripts can be created using the UEFI Shell built-in editor **edit** or under any OS with a plain text editor of your choice.

7.6.3. Example of Startup Scripts

Execute Shell Script on other Harddrive

This example (**startup.nsh**) executes the shell script named **bootme.nsh** located in the root of the first detected disk drive (**fs0**).

```

fs0:
bootme.nsh

```

7.7. Firmware Update

Firmware updates are typically delivered as a ZIP archive. Please find the latest available BIOS-ZIP archive on JUMPtec's [Customer Section](#). Further information about the firmware update procedure can be found in the included "flash_instruction.txt"-file.



Register to JUMPtec's [Customer Section](#) to get access to BIOS downloads, additional documentation and Product Change Notification service.

8/ Technical Support

For technical support contact our Support Department:

- › E-mail: techsupport@jumptec.com

Make sure you have the following information available when you call:

- › Product ID Number (P/N),
- › Serial Number (SN) Module's revision
- › Operating System and Kernel/Build version
- › Software modifications
- › Additional connected hardware/full description of hardware set up



The serial number can be found on the Type Label, located on the product's rear panel.

Be ready to explain the nature of your problem to the service technician.

8.1. Warranty

Due to their limited service life, parts that by their nature are subject to a particularly high degree of wear (wearing parts) are excluded from the warranty beyond that provided by law. This applies to the lithium battery, for example.



If there is a protection label on your product, then the warranty is lost if the product is opened.

8.2. Returning Defective Merchandise

All equipment returned to JUMPtec must have a Return of Material Authorization (RMA) number assigned exclusively by JUMPtec. JUMPtec cannot be held responsible for any loss or damage caused to the equipment received without an RMA number. The buyer accepts responsibility for all freight charges for the return of goods to JUMPtec's designated facility. JUMPtec will pay the return freight charges back to the buyer's location in the event that the equipment is repaired or replaced within the stipulated warranty period. Follow these steps before returning any product to JUMPtec.

4. Visit the RMA Information website: <https://www.jumptec.com/en/support/rma-information>
 5. **Download the RMA Request sheet for JUMPtec GmbH and fill out the form. Take care to include a short detailed description of the observed problem or failure and to include the product identification Information (Name of product, Product number and Serial number). If a delivery includes more than one product, fill out the above information in the RMA Request form for each product.**
 6. Send the completed RMA-Request form to the email address given at JUMPtec GmbH. JUMPtec will provide an RMA-Number.
 7. The goods for repair must be packed properly for shipping, considering shock and ESD protection.
-



Goods returned to JUMPtec GmbH in non-proper packaging will be considered as customer caused faults and cannot be accepted as warranty repairs

8. Include the RMA-Number with the shipping paperwork and send the product to the delivery address provided in the RMA form or received from JUMPtec RMA Support.

9/ Storage and Transportation

9.1. Storage

If the product is not in use for an extended period time, disconnect the power plug from the power supply. If it is necessary to store the product then re-pack the product as originally delivered to avoid damage. The storage facility must meet the products environmental storage requirements as stated within this user guide. JUMPtec recommends keeping the original packaging material for future storage or warranty shipments.

9.2. Transportation

To ship the product use the original packaging, designed to withstand impact and adequately protect the product. When packing or unpacking products always take shock and ESD protection into consideration and use an EOS/ESD safe working area.



About JUMPtec

JUMPtec specializes its technical expertise in designing both – standard and highly customized compute products. Our newly optimized structure enables us to take customers from prototyping and design through to mass production faster than ever before.

JUMPtec serves a diverse range of markets, providing innovative solutions tailored to the unique needs of each industry. Find out more about our offering!

For more information, please visit: www.jumptec.com

JUMPtec GmbH

Brunnwiesenstrasse 16

94469 Deggendorf

Germany

Tel.: + 49 991 37024-0

info@jumptec.com

www.jumptec.com



www.jumptec.com